

# NHD-1.69-160128UGC3

## Graphic Color OLED Display Module

NHD-	Newhaven Display
1.69-	1.69" Diagonal Size
160128-	160 x 128 Pixels
UG-	Model
C-	Full Color
3-	+3V Power Supply

**Newhaven Display International, Inc.**

2661 Galvin Ct.

Elgin IL, 60124

Ph: 847-844-8795

Fax: 847-844-8796

[www.newhavendisplay.com](http://www.newhavendisplay.com)

[nhtech@newhavendisplay.com](mailto:nhtech@newhavendisplay.com)

[nhsales@newhavendisplay.com](mailto:nhsales@newhavendisplay.com)

## Document Revision History

Revision	Date	Description	Changed by
0	3/23/2014	Initial Release	AK

## Functions and Features

- 160 x 128 pixel resolution
- Built-in SEPS525 controller
- Parallel or Serial MPU interface
- Single, low voltage power supply
- RoHS compliant

# Mechanical Drawing

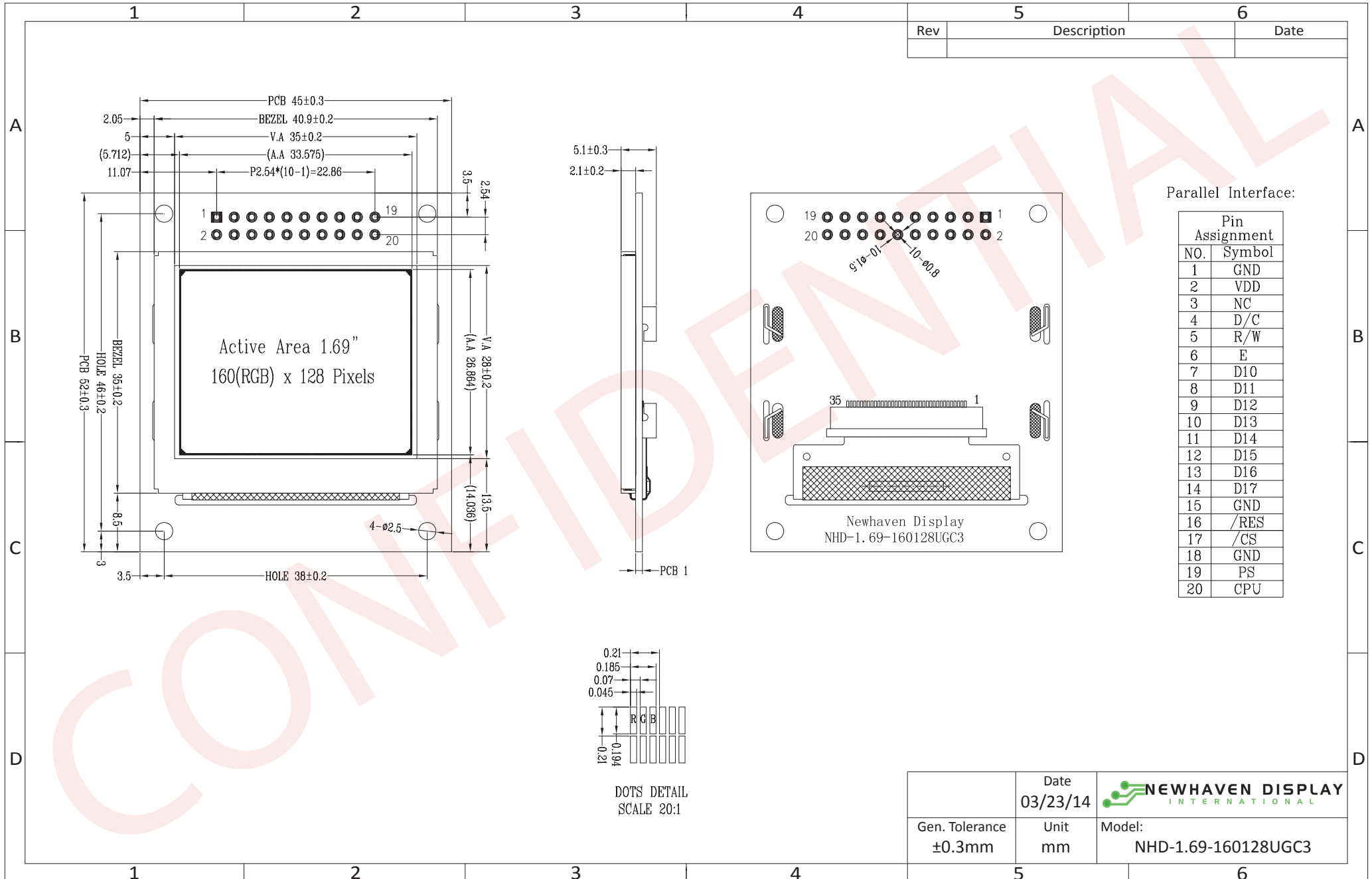

The drawing contained herein is the exclusive property of Newhaven Display International, Inc. and shall not be copied, reproduced, and/or disclosed in any format without permission.

# Interface Description

## Parallel Interface:

Pin No.	Symbol	External Connection	Function Description
1	GND	Power Supply	Ground
2	VDD	Power Supply	Supply Voltage for OLED and logic.
3	NC	-	No Connect
4	D/C	MPU	Register select signal. D/C=0: Command, D/C=1: Data
5	R/W or /WR	MPU	<b>6800-interface:</b> Read/Write select signal, R/W=1: Read R/W: =0: Write <b>8080-interface:</b> Active LOW Write signal.
6	E or /RD	MPU	<b>6800-interface:</b> Operation enable signal. Falling edge triggered. <b>8080-interface:</b> Active LOW Read signal.
7-14	DB10 – DB17	MPU	8-bit Bi-directional data bus lines.
15	GND	Power Supply	Ground
16	/RES	MPU	Active LOW Reset signal.
17	/CS	MPU	Active LOW Chip Select signal.
18	GND	Power Supply	Ground
19	PS	MPU	Parallel/Serial select. HIGH: Parallel. LOW: Serial
20	CPU	MPU	Interface select. HIGH: 6800 interface. LOW: 8080 interface

## Serial Interface:

Pin No.	Symbol	External Connection	Function Description
1	GND	Power Supply	Ground
2	VDD	Power Supply	Supply Voltage for OLED and logic.
3	NC	-	No Connect
4	D/C	MPU	Register select signal. D/C=0: Command, D/C=1: Data Tie LOW for 3-wire Serial Interface.
5-6	VSS	Power Supply	Ground
7-12	GND	Power Supply	Ground
13	SDI	MPU	Serial Data Input signal.
14	SCL	MPU	Serial Clock signal.
15	GND	Power Supply	Ground
16	/RES	MPU	Active LOW Reset signal.
17	/CS	MPU	Active LOW Chip Select signal.
18	GND	Power Supply	Ground
19	PS	MPU	Parallel/Serial select. HIGH: Parallel. LOW: Serial
20	CPU	MPU	Interface select. HIGH: 6800 interface. LOW: 8080 interface

## MPU Interface Pin Assignment Summary

Bus Interface	Data/Command Interface								Control Signals				
	D17	D16	D15	D14	D13	D12	D11	D10	E	R/W	/CS	D/C	/RES
8-bit 6800	D[17:10]								E	R/W	/CS	D/C	/RES
8-bit 8080	D[17:10]								/RD	/WR	/CS	D/C	/RES
4-wire SPI	SCL	SDI	Tie LOW								/CS	D/C	/RES

# Wiring Diagrams

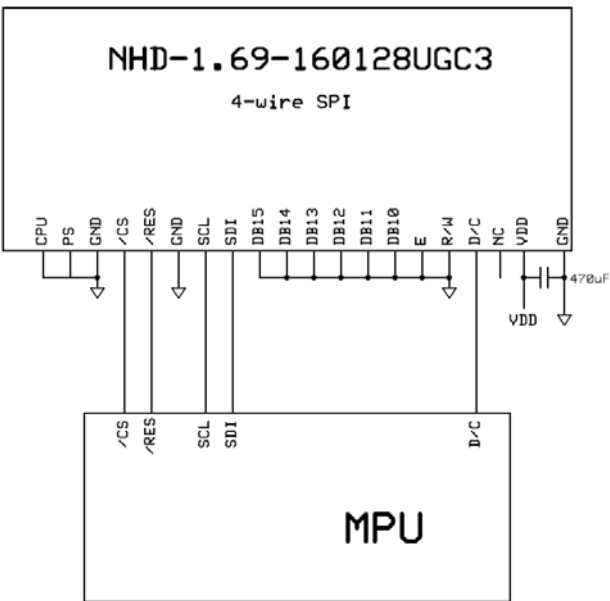
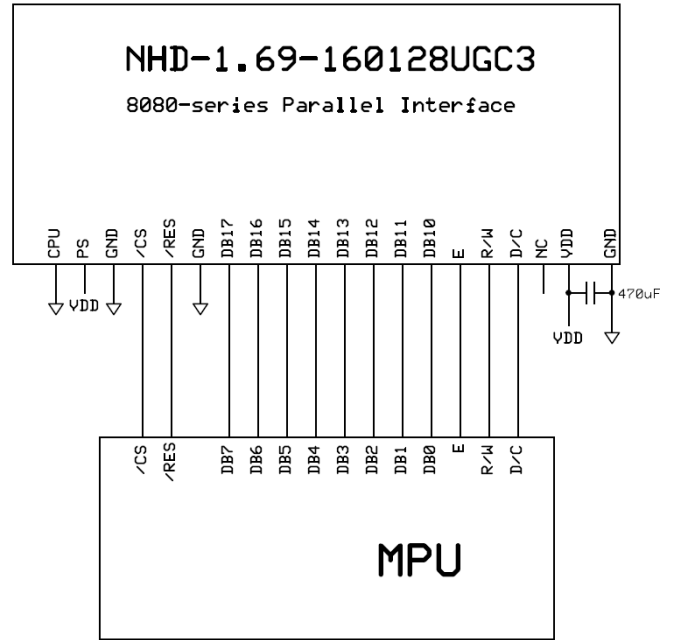
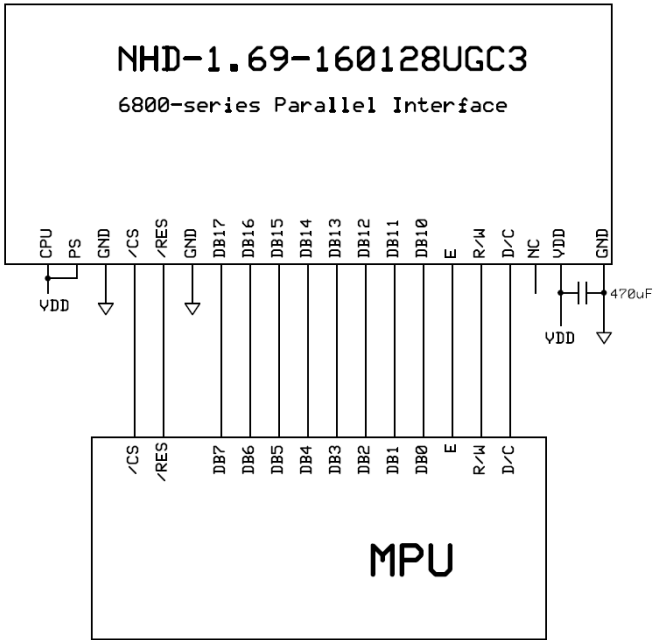

## Electrical Characteristics

Item	Symbol	Condition	Min.	Typ.	Max.	Unit
Operating Temperature Range	Top	Absolute Max	-30	-	+70	°C
Storage Temperature Range	Tst	Absolute Max	-40	-	+80	°C
Supply Voltage	VDD		2.6	2.8	3.3	V
Supply Current (logic)	IDD	VDD=2.8V	-	6	12	mA
Supply Current (display)	ICC	VDD=2.8V	-	180	330	mA
Sleep Mode Current	IDD+ICC <sub>SLEEP</sub>		-	5	10	μA
"H" Level input	Vih		0.8*VDD	-	VDD	V
"L" Level input	Vil		0	-	0.4	V
"H" Level output	Voh		VDD-0.4	-	-	V
"L" Level output	Vol		-	-	0.4	V

## Optical Characteristics

Item	Symbol	Condition	Min.	Typ.	Max.	Unit
Viewing Angle – Top			80	-	-	°
Viewing Angle – Bottom			80	-	-	°
Viewing Angle – Left			80	-	-	°
Viewing Angle – Right			80	-	-	°
Contrast Ratio	Cr		-	2000:1	-	-
Response Time (rise)	Tr	-	-	10	-	us
Response Time (fall)	Tf	-	-	10	-	us
Brightness		50% checkerboard	60	75	-	cd/m <sup>2</sup>
Lifetime		90 cd/m <sup>2</sup> , Ta=25°C, 50% checkerboard	10,000	-	-	Hrs

**Note:** Lifetime at typical temperature is based on accelerated high-temperature operation. Lifetime is tested at average 50% pixels on and is rated as Hours until **Half-Brightness**. The Display OFF command can be used to extend the lifetime of the display.

Luminance of active pixels will degrade faster than inactive pixels. Residual (burn-in) images may occur. To avoid this, every pixel should be illuminated uniformly.

## Controller information

Built-in SEPS525 controller.

Please download specification at [www.newhavendisplay.com/app\\_notes/SEPS525.pdf](http://www.newhavendisplay.com/app_notes/SEPS525.pdf)

# Table of Commands

ADDR	RW	IB7	IB6	IB5	IB4	IB3	IB2	IB1	IB0	Description	Default
00h	R	IDX7	IDX6	IDX5	IDX4	IDX3	IDX2	IDX1	IDX0	INDEX	00h
01h	R	HC	VC	HV	SWAP	RD	CD	DC1	DC0	STATUS_RD	C0h
02h	R/W	SELEXP	SELRES	-	-	-	-	SELCLK	OSCD5B	OSC_CTL	C0h
80h	R/W	-	-	-	-	-	-	-	IREF	IREF	00h
03h	R/W	FR3	FR2	FR1	FR0	DFR3	DFR2	DFR1	DFR0	CLOCK_DIV	30h
04h	R/W	-	-	-	-	-	RC	OSCPS	PS	REDUCE_CURRENT	00h
05h	R/W	-	-	-	-	-	-	-	SRN	SOFT_RST	00h
06h	R/W	PREM	-	-	-	-	-	-	DON	DISP_ON_OFF	00h
08h	R/W	-	-	-	-	PTR3	PTR2	PTR1	PTR0	PRECHARGE_TIME_R	00h
09h	R/W	-	-	-	-	PTG3	PTG2	PTG1	PTG0	PRECHARGE_TIME_G	00h
0Ah	R/W	-	-	-	0	PTB3	PTB2	PTB1	PTB0	PRECHARGE_TIME_B	00h
0Bh	R/W	PCR7	PCR6	PCR5	PCR4	PCR3	PCR2	PCR1	PCR0	PRECHARGE_CURRENT_R	00h
0Ch	R/W	PCG7	PCG6	PCG5	PCG4	PCG3	PCG2	PCG1	PCG0	PRECHARGE_CURRENT_G	00h
0Dh	R/W	PCB7	PCB6	PCB5	PCB4	PCB3	PCB2	PCB1	PCB0	PRECHARGE_CURRENT_B	00h
10h	R/W	DCR7	DCR6	DCR5	DCR4	DCR3	DCR2	DCR1	DCR0	DRIVING_CURRENT_R	00h
11h	R/W	DCG7	DCG6	DCG5	DCG4	DCG3	DCG2	DCG1	DCG0	DRIVING_CURRENT_G	00h
12h	R/W	DCB7	DCB6	DCB5	DCB4	DCB3	DCB2	DCB1	DCB0	DRIVING_CURRENT_B	00h
13h	R/W	SWAP	SM	RD	CD	-	SPT	DC1	DC0	DISPLAY_MODE_SET	00h
14h	R/W	-	-	RIM1	RIM0	-	-	-	EDM	RGB_IF	11h
15h	R/W	RES	RES	ENP	DOP	VSYOEN	RES	RES	RES	RGB_POL	00h
16h	R/W	-	DFM1	DFM0	TRI	-	HC	VC	HV	MEMORY_WRITE_MODE	06h
17h	R/W	MX1_7	MX1_6	MX1_5	MX1_4	MX1_3	MX1_2	MX1_1	MX1_0	MX1_ADDR	00h
18h	R/W	MX2_7	MX2_6	MX2_5	MX2_4	MX2_3	MX2_2	MX2_1	MX2_0	MX2_ADDR	9Fh
19h	R/W	MY1_7	MY1_6	MY1_5	MY1_4	MY1_3	MY1_2	MY1_1	MY1_0	MY1_ADDR	00h
1Ah	R/W	MY2_7	MY2_6	MY2_5	MY2_4	MY2_3	MY2_2	MY2_1	MY2_0	MY2_ADDR	7Fh
20h	R/W	MAC7	MAC6	MAC5	MAC4	MAC3	MAC2	MAC1	MAC0	MEMORY_ACCESS_POINTER X	00h
21h	R/W	MAR7	MAR6	MAR5	MAR4	MAR3	MAR2	MAR1	MAR0	MEMORY_ACCESS_POINTER Y	00h
22h		DDRAM[17:0]								DDRAM_DATA_ACCESS_PORT	
50h	R/W	IGAMMA7	IGAMMA6	IGAMMA5	IGAMMA4	IGAMMA3	IGAMMA2	IGAMMA1	IGAMMA0	GRAY_SCALE_TABLE_INDEX	00h
51h	R/W	DGAMMA7	DGAMMA6	DGAMMA5	DGAMMA4	DGAMMA3	DGAMMA2	DGAMMA1	DGAMMA0	GRAY_SCALE_TABLE_DATA	
28h	R/W	DUTY7	DUTY6	DUTY5	DUTY4	DUTY3	DUTY2	DUTY1	DUTY0	DUTY	7Fh
29h	R/W	DSL7	DSL6	DSL5	DSL4	DSL3	DSL2	DSL1	DSL0	DSL	00h
2Eh	R/W	FAC7	FAC6	FAC5	FAC4	FAC3	FAC2	FAC1	FAC0	D1_DDRAM_FAC	00h
2Fh	R/W	FAR7	FAR6	FAR5	FAR4	FAR3	FAR2	FAR1	FAR0	D1_DDRAM_FAR	00h
31h	R/W	SAC7	SAC6	SAC5	SAC4	SAC3	SAC2	SAC1	SAC0	D2_DDRAM_SAC	00h
32h	R/W	SAR7	SAR6	SAR5	SAR4	SAR3	SAR2	SAR1	SAR0	D2_DDRAM_SAR	00h
33h	R/W	FX1_7	FX1_6	FX1_5	FX1_4	FX1_3	FX1_2	FX1_1	FX1_0	SCR1_FX1	00h
34h	R/W	FX2_7	FX2_6	FX2_5	FX2_4	FX2_3	FX2_2	FX2_1	FX2_0	SCR1_FX2	9Fh
35h	R/W	FY1_7	FY1_6	FY1_5	FY1_4	FY1_3	FY1_2	FY1_1	FY1_0	SCR1_FY1	00h
36h	R/W	FY2_7	FY2_6	FY2_5	FY2_4	FY2_3	FY2_2	FY2_1	FY2_0	SCR1_FY2	7Fh
37h	R/W	SX1_7	SX1_6	SX1_5	SX1_4	SX1_3	SX1_2	SX1_1	SX1_0	SCR2_SX1	00h
38h	R/W	SX2_7	SX2_6	SX2_5	SX2_4	SX2_3	SX2_2	SX2_1	SX2_0	SCR2_SX2	9Fh
39h	R/W	SY1_7	SY1_6	SY1_5	SY1_4	SY1_3	SY1_2	SY1_1	SY1_0	SCR2_SY1	00h
3Ah	R/W	SY2_7	SY2_6	SY2_5	SY2_4	SY2_3	SY2_2	SY2_1	SY2_0	SCR2_SY2	7Fh
3Bh	R/W	-	SSA1	SSA0	-	SSC1	SSC0	-	SSM	SCREEN_SAVER_CONTEROL	00h
3Ch	R/W	SST7	SST6	SST5	SST4	SST3	SST2	SST1	SST0	SS_SLEEP_TIMER	00h
3Dh	R/W	-	-	SMS1	SMS0	-	-	SMP1	SMP0	SCREEN_SAVER_MODE	00h
3Eh	R/W	FSUT7	FSUT6	FSUT5	FSUT4	FSUT3	FSUT2	FSUT1	FSUT0	SS_SCR1_FU	00h
3Fh	R/W	-	-	-	-	FSMS3	FSMS2	FSMS1	FSMS0	SS_SCR1_MXY	00h
40h	R/W	SSUT7	SSUT6	SSUT5	SSUT4	SSUT3	SSUT2	SSUT1	SSUT0	SS_SCR2_FU	00h
41h	R/W	SSMS7	SSMS6	SSMS5	SSMS4	SSMS3	SSMS2	SSMS1	SSMS0	SS_SCR2_MXY	00h
42h	R/W	-	-	SSMD1	SSMD0	-	-	-	-	MOVING_DIRECTION	00h
47h	R/W	ISX1_7	ISX1_6	ISX1_5	ISX1_4	ISX1_3	ISX1_2	ISX1_1	ISX1_0	SS_SCR2_SX1	00h
48h	R/W	ISX2_7	ISX2_6	ISX2_5	ISX2_4	ISX2_3	ISX2_2	ISX2_1	ISX2_0	SS_SCR2_SX2	00h
49h	R/W	ISY1_7	ISY1_6	ISY1_5	ISY1_4	ISY1_3	ISY1_2	ISY1_1	ISY1_0	SS_SCR2_SY1	00h
4Ah	R/W	ISY2_7	ISY2_6	ISY2_5	ISY2_4	ISY2_3	ISY2_2	ISY2_1	ISY2_0	SS_SCR2_SY2	00h

# Timing Characteristics

## 6800-Series MCU Parallel Interface:

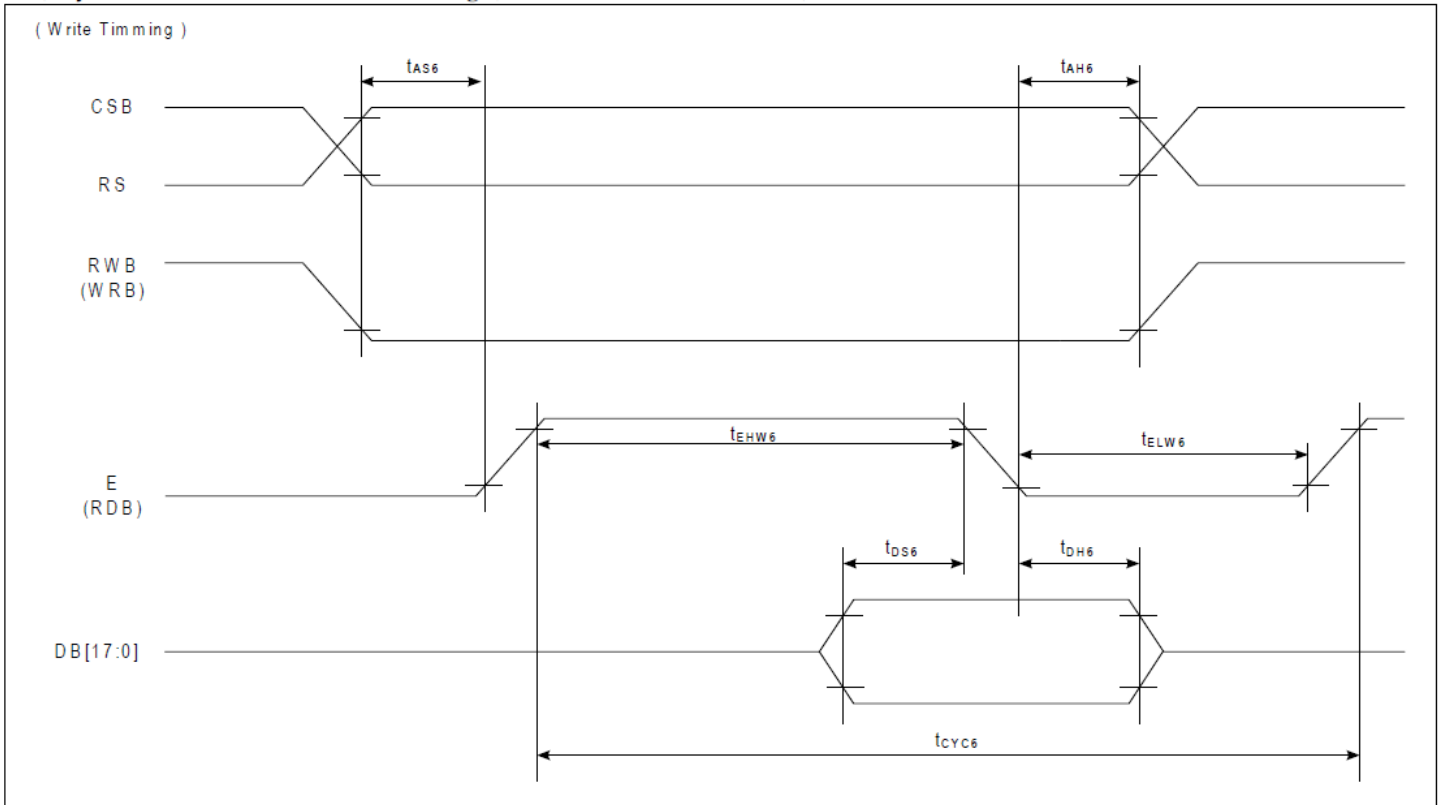

ITEM	SYMBOL	CONDITION	MIN	MAX	UNIT	PORT
Address hold timing	$t_{AH6}$	-	5	-	ns	CSB
Address setup timing	$t_{AS6}$	-	5	-	ns	RS
System cycle timing	$t_{CYC6}$	-	100	-	ns	
Write "L" pulse width	$t_{ELW6}$	-	45	-	ns	E
Write "H" pulse width	$t_{EHW6}$	-	45	-	ns	
Data setup timing	$t_{DS6}$	-	40	-	ns	DB[17:0]
Data hold timing	$t_{DH6}$	-	10	-	ns	



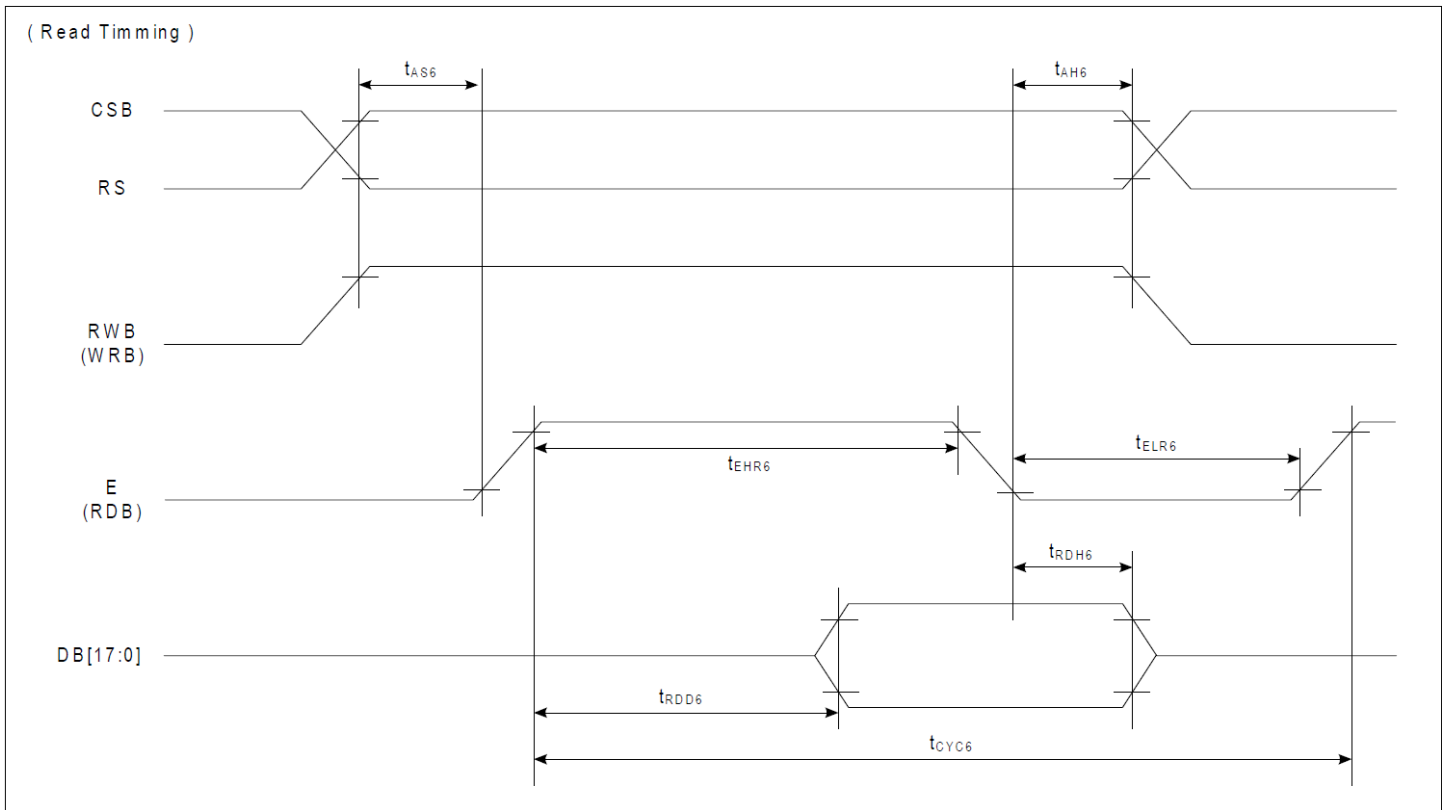

ITEM	SYMBOL	CONDITION	MIN	MAX	UNIT	PORT
Address hold timing	$t_{AH6}$	-	10	-	ns	CSB
Address setup timing	$t_{AS6}$	-	10	-	ns	RS
System cycle timing	$t_{CYC6}$	-	200	-	ns	
Read "L" pulse width	$t_{ELR6}$	-	90	-	ns	E
Read "H" pulse width	$t_{EHR6}$	-	90	-	ns	
Read data output delay time	$t_{RDD6}$	CL = 15 pF	0	70	ns	DB[17:0]
Data hold timing	$t_{RDH6}$				ns	

## 8080-Series MCU Parallel Interface:

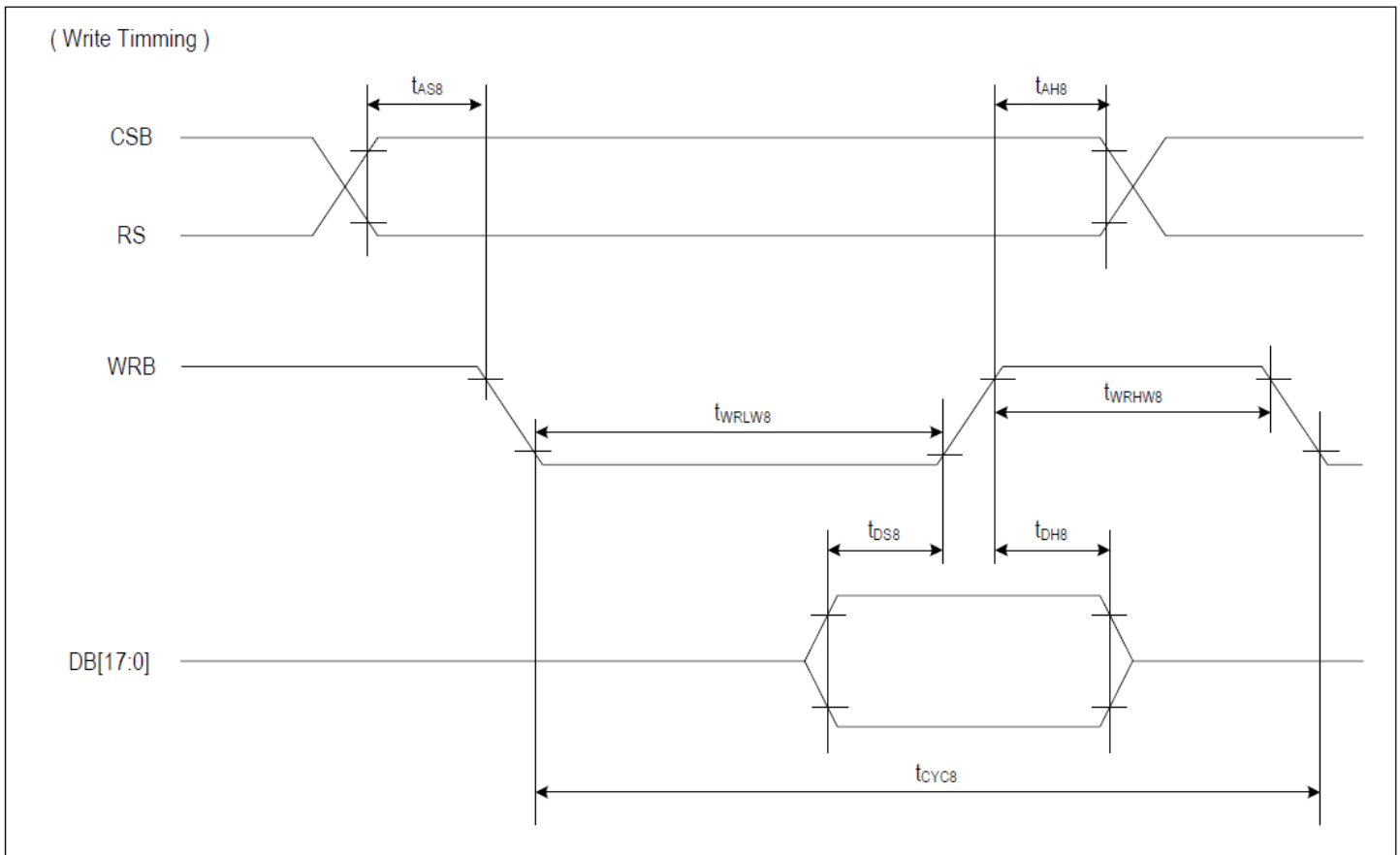

ITEM	SYMBOL	CONDITION	MIN	MAX	UNIT	PORT
Address hold timing	$t_{AH8}$	-	5	-	ns	CSB
Address setup timing	$t_{AS8}$	-	5	-	ns	RS
System cycle timing	$t_{CYC8}$	-	100	-	ns	
Write "L" pulse width	$t_{WRLW8}$	-	45	-	ns	WRB
Write "H" pulse width	$t_{WRHW8}$	-	45	-	ns	
Data setup timing	$t_{DS8}$	-	30	-	ns	DB[17:0]
Data hold timing	$t_{DH8}$	-	10	-	ns	

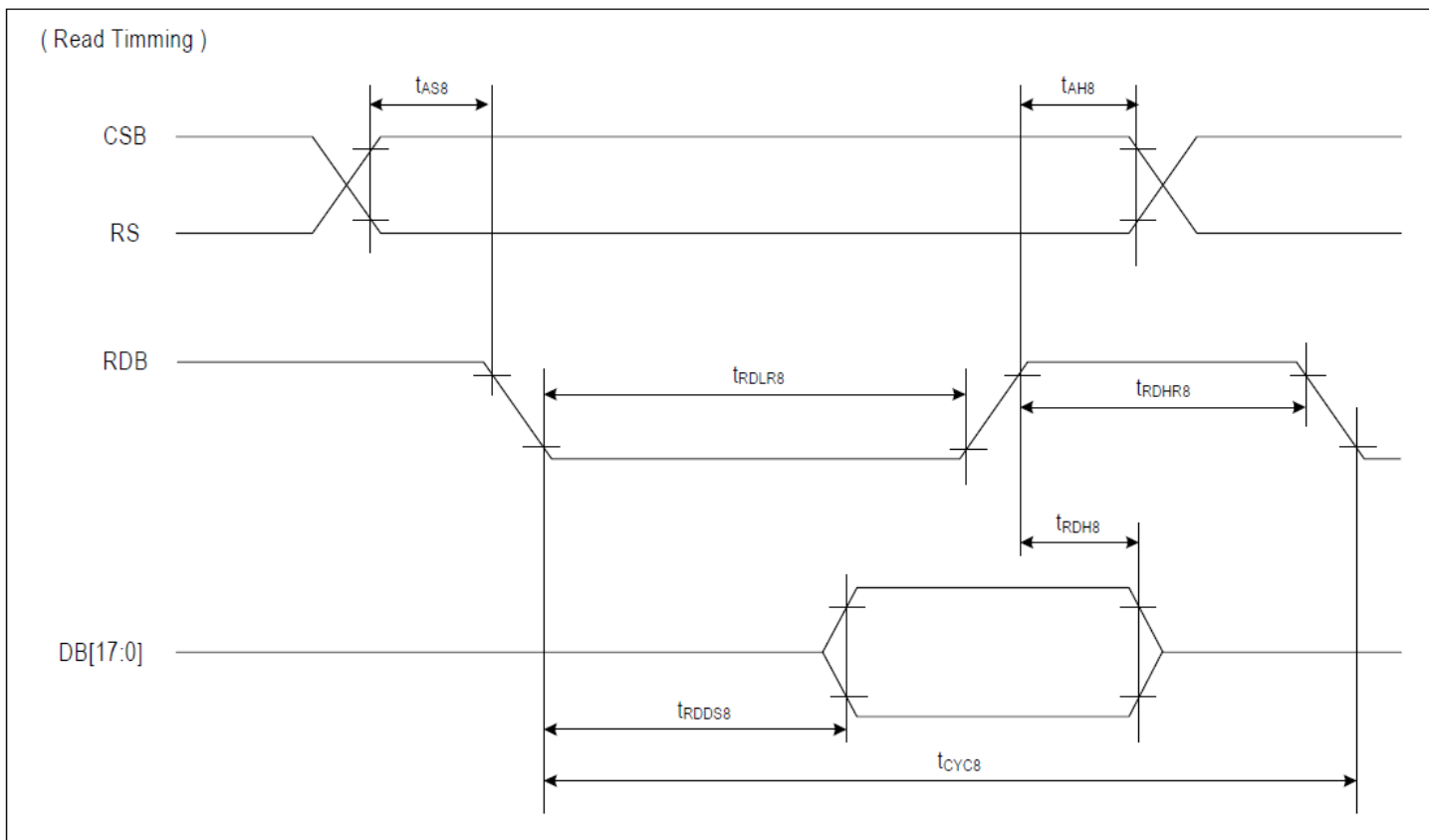

ITEM	SYMBOL	CONDITION	MIN	MAX	UNIT	PORT
Address hold timing	$t_{AH8}$	-	5	-	ns	CSB
Address setup timing	$t_{AS8}$	-	5	-	ns	RS
System cycle timing	$t_{CYC8}$	-	200	-	ns	
Read "L" pulse width	$t_{RDLR8}$	-	90	-	ns	RDB
Read "H" pulse width	$t_{RDHR8}$	-	90	-	ns	
Read data output delay time	$t_{RDDS8}$	CL = 15 pF	-	60	ns	DB[17:0]
Data hold timing	$t_{RDH8}$	CL = 15 pF	0	-	ns	

## 4-wire SPI:

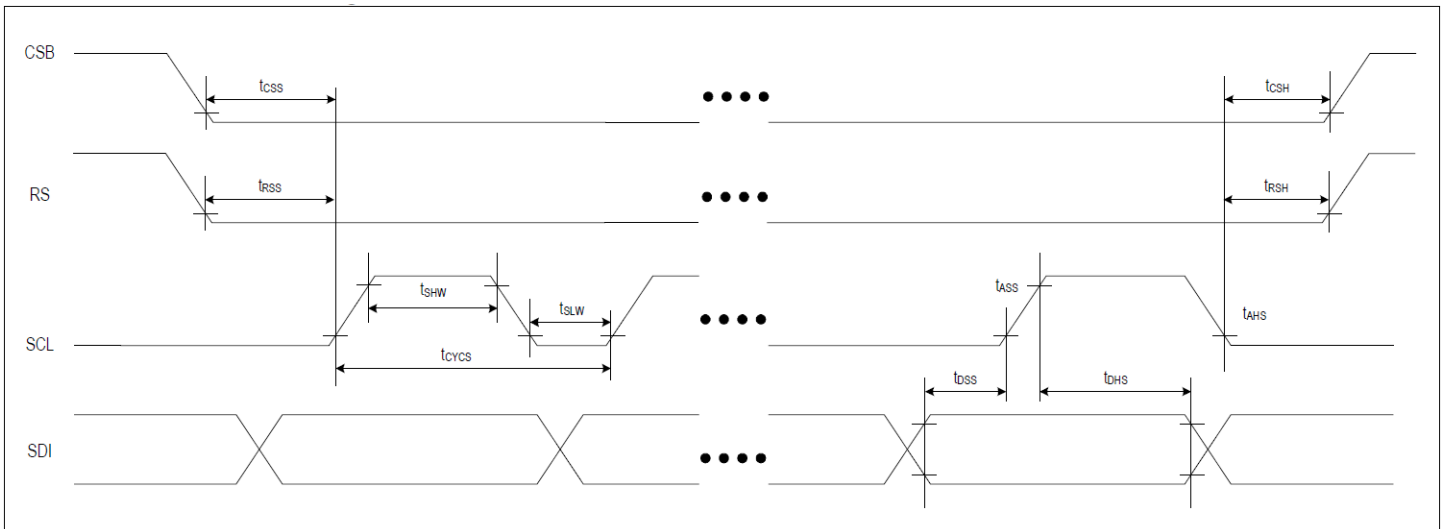

ITEM	SYMBOL	CONDITION	MIN	MAX	UNIT	PORT
Serial clock cycle	$t_{CYCS}$		100		ns	SCL
SCL "H" pulse width	$t_{SHW}$	-	45	-	ns	SCL
SCL "L" pulse width	$t_{SLW}$		45		ns	SCL
Data setup timing	$t_{DSS}$	-	5	-	ns	SDI
Data hold timing	$t_{DHS}$		5		ns	SDI
CSB-SCL timing	$t_{CSS}$	-	5	-	ns	CSB
CSB-hold timing	$t_{CSSH}$		5		ns	CSB
RS-SCL timing	$T_{RSS}$	-	5	-	ns	RS
RS-hold timing	$T_{RSH}$		5		ns	RS

## Example Initialization Sequence:

```
void oled_Data_160128RGB(unsigned char Data)
{
  GPIO_ResetBits(GPIOC, CS1);
  GPIO_SetBits(GPIOC, RS);
  GPIO_Write(GPIOB, Data);
  GPIO_ResetBits(GPIOC, RW);
  GPIO_SetBits(GPIOC, E1);
  GPIO_ResetBits(GPIOC, E1);
}
```

```
void oled_Command_160128RGB(unsigned char Data)
{
  GPIO_ResetBits(GPIOC, CS1);
  GPIO_ResetBits(GPIOC, RS);
  GPIO_Write(GPIOB, Data);
  GPIO_ResetBits(GPIOC, RW);
  GPIO_SetBits(GPIOC, E1);
  GPIO_ResetBits(GPIOC, E1);
}
```

```
void OLED_Init_160128RGB(void)
{
  int i,j;
  GPIO_ResetBits(GPIOC, RES);
  graphic_delay(500000);
  GPIO_SetBits(GPIOC, RES);
  graphic_delay(500000);
```

```
oled_Command_160128RGB(0x04); // Set Normal Driving Current
oled_Data_160128RGB(0x03); // Disable Oscillator Power Down
graphic_delay(2000);
```

```
oled_Command_160128RGB(0x04); // Enable Power Save Mode
oled_Data_160128RGB(0x00); // Set Normal Driving Current
graphic_delay(2000); // Disable Oscillator Power Down
```

```
oled_Command_160128RGB(0x3B);
oled_Data_160128RGB(0x00);
```

```
oled_Command_160128RGB(0x02);
oled_Data_160128RGB(0x01); // Set EXPORT1 Pin at Internal Clock
// Oscillator operates with external resister.
// Internal Oscillator On
```

```
oled_Command_160128RGB(0x03);
oled_Data_160128RGB(0x90); // Set Clock as 90 Frames/Sec
```

```

oled_Command_160128RGB(0x80);
oled_Data_160128RGB(0x01);           // Set Reference Voltage Controlled by External Resister

oled_Command_160128RGB(0x08);// Set Pre-Charge Time of Red
oled_Data_160128RGB(0x04);
oled_Command_160128RGB(0x09);// Set Pre-Charge Time of Green
oled_Data_160128RGB(0x05);
oled_Command_160128RGB(0x0A);// Set Pre-Charge Time of Blue
oled_Data_160128RGB(0x05);

oled_Command_160128RGB(0x0B);// Set Pre-Charge Current of Red
oled_Data_160128RGB(0x9D);
oled_Command_160128RGB(0x0C);// Set Pre-Charge Current of Green
oled_Data_160128RGB(0x8C);
oled_Command_160128RGB(0x0D);// Set Pre-Charge Current of Blue
oled_Data_160128RGB(0x57);

oled_Command_160128RGB(0x10);// Set Driving Current of Red
oled_Data_160128RGB(0x56);
oled_Command_160128RGB(0x11);// Set Driving Current of Green
oled_Data_160128RGB(0x4D);
oled_Command_160128RGB(0x12);// Set Driving Current of Blue
oled_Data_160128RGB(0x46);

oled_Command_160128RGB(0x13);
oled_Data_160128RGB(0xa0);           // Set Color Sequence

oled_Command_160128RGB(0x14);
oled_Data_160128RGB(0x01);           // Set MCU Interface Mode
oled_Command_160128RGB(0x16);
oled_Data_160128RGB(0x76);

oled_Command_160128RGB(0x20);
oled_Data_160128RGB(0x00);           // Shift Mapping RAM Counter
oled_Command_160128RGB(0x21);
oled_Data_160128RGB(0x00);           // Shift Mapping RAM Counter

oled_Command_160128RGB(0x28);
oled_Data_160128RGB(0x7F);           // 1/128 Duty (0x0F~0x7F)

oled_Command_160128RGB(0x29);
oled_Data_160128RGB(0x00);           // Set Mapping RAM Display Start Line (0x00~0x7F)

oled_Command_160128RGB(0x06);
oled_Data_160128RGB(0x01);           // Display On (0x00/0x01)

oled_Command_160128RGB(0x05);           // Disable Power Save Mode
oled_Data_160128RGB(0x00);           // Set All Internal Register Value as Normal Mode

```

```

oled_Command_160128RGB(0x15);
oled_Data_160128RGB(0x00);           // Set RGB Interface Polarity as Active Low

}

int oled_160128RGB(void)
{
oled_Command_160128RGB(0x17);   //set column start address
oled_Data_160128RGB(0x00);     //

oled_Command_160128RGB(0x18);   //set column end address
oled_Data_160128RGB(0x9F);     //

oled_Command_160128RGB(0x19);   //set row start address
oled_Data_160128RGB(0x00);     //

oled_Command_160128RGB(0x1A);   //set row end address
oled_Data_160128RGB(0x7F);     //

oled_Command_160128RGB(0x22);   //write to RAM command

for (i=0;i<20480;i++)   //for each 24-bit pixel...160*128=20480
{
    oled_Data_160128RGB(red);
    oled_Data_160128RGB(green);
    oled_Data_160128RGB(blue);
}

/*if(image==screenSaverRequired){           //screen saver example--!
    //First Screen
    oled_Command_160128RGB(0x2E);   //first screen horizontal address
    oled_Data_160128RGB(0x00);     //
    oled_Command_160128RGB(0x2F);   //first screen vertical address
    oled_Data_160128RGB(0x00);     //
    oled_Command_160128RGB(0x33);   //first screen start column
    oled_Data_160128RGB(0x00);     //
    oled_Command_160128RGB(0x34);   //first screen end column
    oled_Data_160128RGB(0x9F);     //
    oled_Command_160128RGB(0x35);   //first screen start row
    oled_Data_160128RGB(0x00);     //
    oled_Command_160128RGB(0x36);   //first screen end row
    oled_Data_160128RGB(0x36);     //

    //Second_Screen(0x00,0x9F,0x3C,0x7F,0x20,0x7F,0x3C,0x5F);
    oled_Command_160128RGB(0x31);   //second screen horizontal address
    oled_Data_160128RGB(0x00);     //
    oled_Command_160128RGB(0x32);   //second screen vertical address

```

```

oled_Data_160128RGB(0x37);      //
oled_Command_160128RGB(0x37);  //second screen start column
oled_Data_160128RGB(0x00);      //
oled_Command_160128RGB(0x38);  //second screen end column
oled_Data_160128RGB(0x9F);      //
oled_Command_160128RGB(0x39);  //second screen start row
oled_Data_160128RGB(0x37);      //
oled_Command_160128RGB(0x3A);  //second screen end row
oled_Data_160128RGB(0x7F);      //
oled_Command_160128RGB(0x47);  //second screen      box start column
oled_Data_160128RGB(0x60);      //
oled_Command_160128RGB(0x48);  //second screen box end column
oled_Data_160128RGB(0x7F);      //
oled_Command_160128RGB(0x49);  //second screen box start row
oled_Data_160128RGB(0x37);      //
oled_Command_160128RGB(0x4A);  //second screen box end row
oled_Data_160128RGB(0x37);      //

oled_Command_160128RGB(0x3E);  //first screen update timer
oled_Data_160128RGB(0x04);
oled_Command_160128RGB(0x3F);  //horizontal step
oled_Data_160128RGB(0x01);
oled_Command_160128RGB(0x40);  //second screen update timer
oled_Data_160128RGB(0x01);
oled_Command_160128RGB(0x41);  //second screen vertical and horizontal step
oled_Data_160128RGB(0x11);
oled_Command_160128RGB(0x42);  //moving direction
oled_Data_160128RGB(0x00);
oled_Command_160128RGB(0x3C);  //sleep timer
oled_Data_160128RGB(0xF0);
oled_Command_160128RGB(0x3D);  //Screen saver      mode
oled_Data_160128RGB(0x01);
oled_Command_160128RGB(0x13);
oled_Data_160128RGB(0xa4);
oled_Command_160128RGB(0x3B);  //Screen saver control
oled_Data_160128RGB(0x0D);
} */
/*else {                          //Screen Saver example #2--!
oled_Command_160128RGB(0x2E);  //First Screen      First_Screen(0x00,0x9F,0x00,0x7F);
oled_Data_160128RGB(0x00);      //
oled_Command_160128RGB(0x2F);  //
oled_Data_160128RGB(0x00);      //
oled_Command_160128RGB(0x33);  //
oled_Data_160128RGB(0x00);      //
oled_Command_160128RGB(0x34);  //
oled_Data_160128RGB(0x9F);      //
oled_Command_160128RGB(0x35);  //
oled_Data_160128RGB(0x00);      //
oled_Command_160128RGB(0x36);  //
oled_Data_160128RGB(0x7F);      //

```



```

oled_Command_160128RGB(0x13);
oled_Data_160128RGB(0xa0);
//Screen_Saver_(full screen to the right)
oled_Command_160128RGB(0x3E);//Screen saver
oled_Data_160128RGB(0x01);
oled_Command_160128RGB(0x3F);//Screen saver
oled_Data_160128RGB(0x01);
oled_Command_160128RGB(0x40);//Screen saver
oled_Data_160128RGB(0x01);
oled_Command_160128RGB(0x41);//Screen saver
oled_Data_160128RGB(0x01);
oled_Command_160128RGB(0x42);//Screen saver
oled_Data_160128RGB(0x10);
oled_Command_160128RGB(0x3C);//Screen saver timer
oled_Data_160128RGB(0x80);
oled_Command_160128RGB(0x3D);//Screen saver timer
oled_Data_160128RGB(0x32);
oled_Command_160128RGB(0x3B);//Screen saver
oled_Data_160128RGB(0x05);
}*/

```

```

/* //turn off screen saver example --!
oled_Command_160128RGB(0x3D);//Screen saver timer
oled_Data_160128RGB(0x00);
oled_Command_160128RGB(0x3C);//Screen saver timer
oled_Data_160128RGB(0x00);
oled_Command_160128RGB(0x3B);//Screen saver
oled_Data_160128RGB(0x00);
oled_Command_160128RGB(0x42);//Screen saver
oled_Data_160128RGB(0x00);
*/

```

```

}return 1;}

```

```

////////////////////////////////////

```

## Quality Information

Test Item	Content of Test	Test Condition	Note
High Temperature storage	Test the endurance of the display at high storage temperature.	+80°C , 96hrs	2
Low Temperature storage	Test the endurance of the display at low storage temperature.	-40°C , 96hrs	1,2
High Temperature Operation	Test the endurance of the display by applying electric stress (voltage & current) at high temperature.	+70°C 96hrs	2
Low Temperature Operation	Test the endurance of the display by applying electric stress (voltage & current) at low temperature.	-30°C , 96hrs	1,2
High Temperature / Humidity Operation	Test the endurance of the display by applying electric stress (voltage & current) at high temperature with high humidity.	+60°C , 90% RH , 96hrs	1,2
Thermal Shock resistance	Test the endurance of the display by applying electric stress (voltage & current) during a cycle of low and high temperatures.	-30°C,30min -> 25°C,5min -> 70°C,30min = 1 cycle 100 cycles	
Vibration test	Test the endurance of the display by applying vibration to simulate transportation and use.	10-22Hz , 15mm amplitude. 22-500Hz, 1.5G 30min in each of 3 directions X,Y,Z	3
Atmospheric Pressure test	Test the endurance of the display by applying atmospheric pressure to simulate transportation by air.	115mbar, 40hrs	3
Static electricity test	Test the endurance of the display by applying electric static discharge.	VS=800V, RS=1.5kΩ, CS=100pF One time	

**Note 1:** No condensation to be observed.

**Note 2:** Conducted after 2 hours of storage at 25°C, 0%RH.

**Note 3:** Test performed on product itself, not inside a container.

### Evaluation Criteria:

- 1: Display is fully functional during operational tests and after all tests, at room temperature.
- 2: No observable defects.
- 3: Luminance >50% of initial value.
- 4: Current consumption within 50% of initial value

## Precautions for using OLEDs/LCDs/LCMs

See Precautions at [www.newhavendisplay.com/specs/precautions.pdf](http://www.newhavendisplay.com/specs/precautions.pdf)

## Warranty Information and Terms & Conditions

[http://www.newhavendisplay.com/index.php?main\\_page=terms](http://www.newhavendisplay.com/index.php?main_page=terms)