

Products designed for extreme washdown environments

IP69K Products

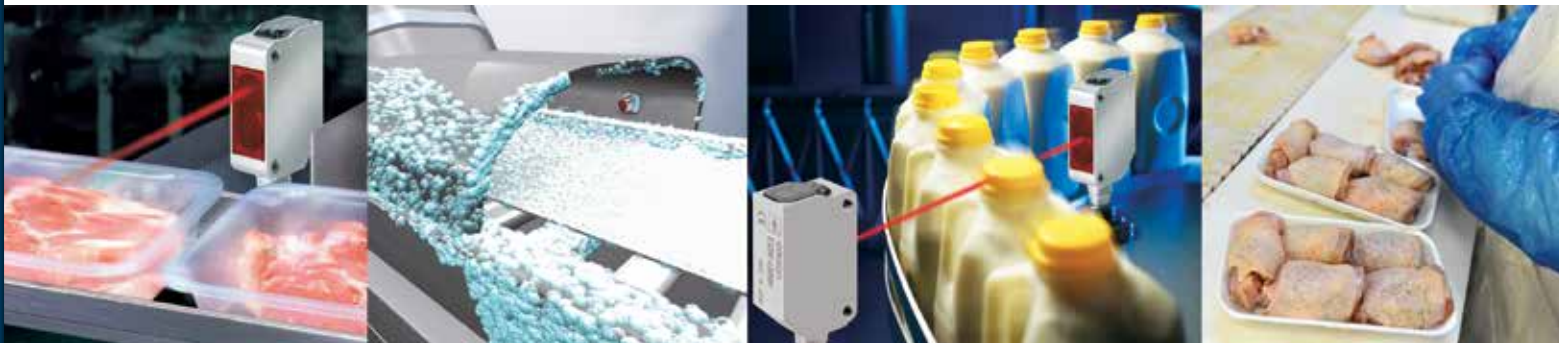

- » Innovative technologies
- » Easy to use, install and integrate
- » Powerful solutions

Omron delivers a wide range of solutions for washdown resistant products from a single source

Omron has been providing automation solutions for more than 80 years. Our washdown rated products and extreme washdown products in the IP69K protection class help you deliver safer solutions to your customers.

We bring expertise in the food processing / packaging, automotive, semiconductor, infrastructure, and the oil and gas industries. Our products are supported globally wherever your machine may ship.

Our IP69K products can withstand harsh washdown environments to ensure food safety conditions are met regarding:

Cleanability – rounded and sealed construction to allow high washdown pressures at any angle. They also allow for cleaning using aggressive cleaning solutions.

Validated Cleaning and Sanitizing Protocols – Our IP69K products can withstand high and low ambient operating conditions as well as washdown in extreme environments and maintain integrity.

Industries/Applications

- Dairy
- Poultry Processing
- Beef Processing
- Pre-Packaged Food Packaging

Benefits

- “One stop shop” Omron offers a variety of product solutions from light washdown to extreme IP69K class products
- Global Technical Support – your questions are answered anywhere in the world

Dairy



Poultry Processing



Beef Processing



Washdown Operation

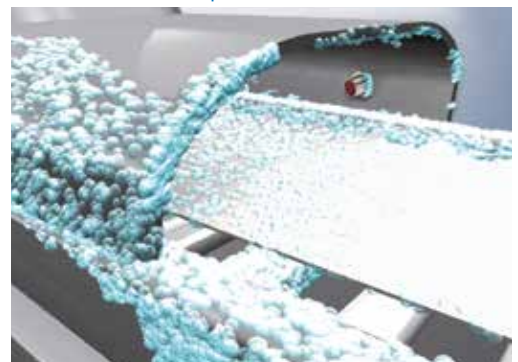

Control

Sensors

E3FA/E3RA

High performance photoelectric sensor in compact M18 housing



The E3FA/E3RA family provides a wide range of high quality M18 cylindrical sensors, with models designed for standard or special applications.

- Simplicity in selection and installation
- Compact size with flush mounting option
- IP67, IP69K for wash down resistance
- Straight or Radial models in cylindrical M18 plastic housing
- Background suppression, Limited Distance and Transparent detection models available

Sensors

E3FB/E3RB

High performance photoelectric sensor in compact M18 housing

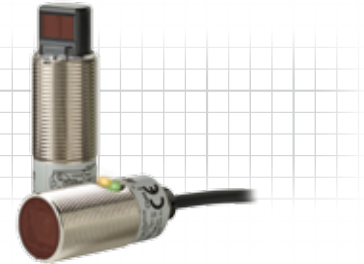

The E3FB/E3RB family provides a wide range of high quality M18 cylindrical sensors, with models designed for standard or special applications.

- Nickel-plated brass housing
- Compact size with pre-wired or M12 connector options
- IP67, IP69K for water and wash down resistance
- Straight or Radial models in cylindrical M18 housing
- Background suppression, Limited Distance and Transparent detection models available

Sensors

E3FC

M18 Photosensor in high-grade stainless steel housing



The E3FC represents a compact M18 sensor with high housing protection for wash-down applications in Food & Beverage industry.

- High grade steel housing (SUS316L)
- Proven with various industrial detergents of Ecolab and Diversey
- Withstands heat shock conditions
- Epoxy resin at connector/cable end preventing water ingress
- Bright visible red LED enabling easy alignment

Sensors

E3ZM

Photoelectric sensor in compact stainless steel housing



This high-temperature, high-pressure photoelectric sensor is designed with a food grade 316L stainless steel housing.

- High grade stainless steel housing (SUS316L)
- IP67 and IP69K for wash down resistance
- Ecolab tested and certified detergent resistance
- Laser-etched part number and markings
- Switch-selectable Light-On/Dark-On operation

Control

Sensors

E3ZM-B

Transparent object detection sensor in compact stainless steel housing



The E3ZM-B family provides models for general transparent material detection as well as specialized models providing the highest stability for detection of PET bottles.

- Reliably detects PET and thin wall plastic bottles
- Detergent-resistant compact SUS316L housing
- Includes Bi-refringent, P-opaquiring technology
- IP69K rated housing for high pressure wash down

Sensors

E3S-DB

Superb Detection of Many Types of Transparent Objects



High detection capabilities for stable detection of a wide range of transparent workpieces in the food and packaging industries, including glass bottles, PET bottles, films and trays. You can increase equipment operating rates and reduce commissioning and maintenance work.

- Double-slit optical design ensures reception of only parallel light to stabilize detection.
- P-opaquiring function ensures attenuation of 70% even on films with little difference in light levels.
- Narrow beam enables incident light with gaps as narrow as 3mm.
- Visible spot in the reflector lets you easily adjust the optical axis.
- Large indicators are easy to see from any angle.
- IP69K water resistance withstands harsh environments.
- Resistance to detergents certified by Ecolab.

Sensors

E3FM-C

Oil-resistant photoelectric sensor in compact stainless steel housing



This oil-resistant, compact photoelectric sensor in a robust stainless steel housing features reliable object detection in dirty and mechanically demanding environments such as automotive assembly lines.

- Oil-resistant stainless steel housing
- IP67 and IP69K for wash down resistance
- High-visibility orange LED on through beam model for easy alignment

Sensors

E3Z-F

Rectangular Body with M18 Barrel Nose for Flexible Mounting

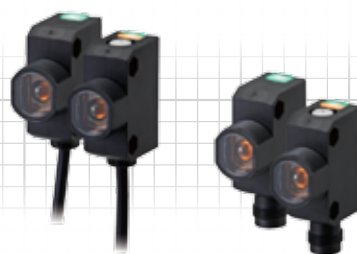

The new E3Z-F shaped series is added to the wide Omron E3Z offerings.

- Visible red LED for easier alignment and trouble-shooting
- E3Z-F is available in Through-beam, Diffuse and polarized Retro-Reflective
- Diffuse-reflective: 100mm, 300mm, 500mm, 1m
- Through-beam: 20m, Retro-reflective: 4m

Control

Sensors

E3ZM-V

Print mark detection photoelectric sensor in compact stainless steel housing

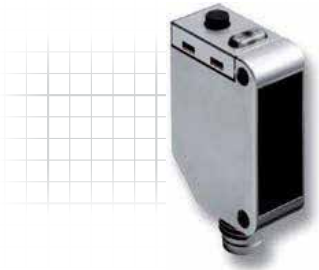

The detergent resistant photoelectric sensor in a robust stainless steel housing provides reliable detection of all common print marks in food packaging applications.

- White LED for stable detection of differently colored or black print marks
- SUS 316L stainless steel housing
- Easy-to-use teach-in button
- Fast response time of 50µs

Sensors

E2A - DC 3-Wire

Long Distance, Short Barrel Cylindrical Inductive DC 3-wire



The long Range Proximity Sensor with Threaded Nickel Plated Brass & Stainless Steel Housing.

- 1.5 to 2 times longer sensing distance compared with CENELEC standard
- 360 degree view of yellow operation indicator
- Built-in circuit protection
- Standard sizes: M8, M12, M18 and M30
- Normally Open and Normally Closed Available
- Stainless steel or Nickel-Plated Brass body

Sensors

E2A3

Long Distance Inductive Proximity Sensor in Cylindrical Brass Housing



The E2A3 family features optimized sensing performance to achieve triple sensing distance for flush mounting requirements.

- Triple distance for enhanced sensor protection from mechanical damage
- Stainless steel and brass housings available
- IP67 and IP69K enclosure rated

Sensors

E2EH

Heat and detergent resistant inductive sensor in cylindrical stainless steel housing



The heat and detergent resistant inductive sensors provide reliable metal object or machine part detection in demanding environments such as food processing.

- Temperature resistant up to 120°C
- SUS316L housing with heat resistant plastic sensing face
- IP69K for highest water resistance
- ECOLAB tested and certified detergent resistance

Control

Sensors

E2Q5

Long Distance Square Inductive Proximity Sensor

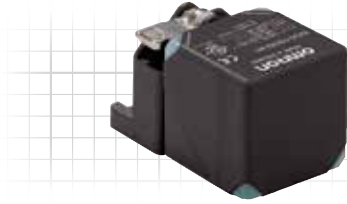

The long sensing distance and simple installation on flat surfaces make the E2Q5 ideal for detection of large metal objects, such as parts in automotive assembly lines.

- M12 Plug-in connection
- Long 40 mm sensing distance
- Integrated short circuit and reverse polarity protection
- Active face position: Y-axis 15°, X-axis 90° increments

Sensors

Y92E-S/Y92E-S_PP

Detergent Resistant Cable Connectors



IP69K Rated Sensor Connector Cordsets for Food, Beverage, Pharma applications.

A complete detergent and wash-down resistant sensing solution of sensor connector cordsets.

- 3-Pin and 4-Pin Connectors, M8 and M12 Sizes
- Food Grade SUS316L Ferrules
- Use with Chemical resistant Photoelectric and Inductive sensors – E3FC, E3ZM and E2EH
- Straight and Angled Connectors

Y92E-S

- Wide Operating Temp Range - -25°C to 70°C
- PVC Cable Material

Y92E-S_PP

- Wide Operating Temp Range - -30°C to 90°C
- Polypropylene Connector Support and cable material
- ECOLAB approved

Robot

Delta Robot IP69K

The fastest picking system integrated in the Sysmac platform

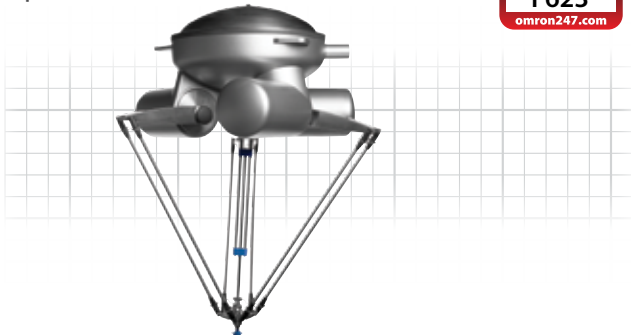

- Rated working range: Ø 1,100 x 250 mm (Max. 400)
- Max. Payload: 3 kg
- Cycle time 25/305/25 mm (0.1 kg): Up to 150 cycle/min
- Protection class: IP69K

Protective Structure

Note: IP-□□ is based on the following testing method. Please verify sealing in the actual environment and conditions of use before using.

IEC (International Electrotechnical Commission) Standards (IEC60529:2001)

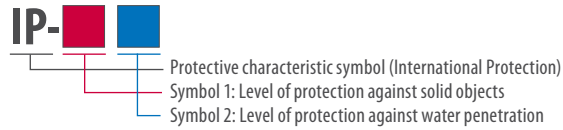

Level		Amount of protection
0		No protection.
1		Solid objects 50 mm or larger in diameter (hand, etc.) do not penetrate.
2		Solid objects 12.5 mm or larger in diameter do not penetrate.
3		Wires or other solid objects 2.5 mm or larger in diameter do not penetrate.
4		Wires or other solid objects 1 mm or larger in diameter do not penetrate.
5		An amount of dust sufficient to interfere with normal operation of the device or create a safety problem does not enter.
6		Dust does not enter.

JEM (Japan Electrical Manufacturers Association) Standards (JEM1030:1991)

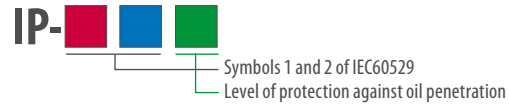

Level		Amount of protection
f	Oil resistant	Suffers no damaging effects from oil drop or oil spray incident from any direction.
g	Oil proof	Oil drops or oil spray incident from any direction does not penetrate.

Note: Other levels (h, c, d and e) also exist.

NEMA (National Electrical Manufacturers Association) Table for converting NEMA enclosures to IEC60529

(conversion from IEC60529 to NEMA is not possible)

Nema 250	IEC 60529	Nema 250	IEC 60529
1	IP10	4, 4X	IP56
2	IP11	5	IP52
3	IP54	6, 6P	IP67
3R	IP14	12, 12K	IP52
3S	IP54	13	IP54

Note: From Appendix A of NEMA standard 250. NEMA enclosure levels and IEC60529 differ in the areas of corrosion resistance, rust resistance, and icing characteristics.

Level		Amount of protection		
0	No special protection.	No protection against water penetration.	No test	
1		Suffers no damaging effects from vertically dripping water.	Placed under vertically dripping water from a drip-ping tester for 10 minutes.	
2		Suffers no damaging effects from water dripping no more than 15° out of plumb.	Placed at an inclination of 15° under dripping water from a dripping tester for 10 minutes (2.5 minutes in each direction).	
3		Suffers no damaging effects from water sprayed from an angle up to 60° from plumb.	Using the tester at right, the device is sprayed from each side up to an angle of 60° from plumb for 10 minutes.	
4		Suffers no damaging effects from water sprayed from all directions.	Using the tester at right, the device is sprayed from all directions for 10 minutes.	
5		Suffers no damaging effects from and direct jet spray from all directions.	Using the tester at right, each square meter of the case is sprayed from all directions for 1 minute, for a total of at least 3 minutes.	
6		Suffers no damaging effects from strong and direct jet spray from all directions.	Using the tester at right, each square meter of the case is sprayed from all directions for 1 minute, for a total of at least 3 minutes.	
7		Water does not penetrate when the device is submerged for a specified amount of time at a specified pressure.	The device is submerged for 10 minutes at depth of 1m in water (if the height of the device is less than 850 mm).	
8		The device can be used on a regular basis under water.	Decided by the manufacturer and the user of het device.	

IP69K according to DIN40 050/9

The IP69K test according to DIN 40 050 part 9 is intended to simulate high pressure / steam cleaning. During the test 14-16 l/min water at 80° C is sprayed onto the sensor from different angles with 8000-10000kPa. The sensor may not suffer any damaging effects from high pressure water in appearance and functionality.

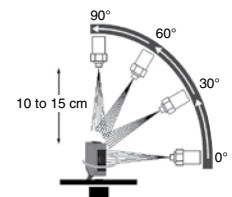

OMRON AUTOMATION AND SAFETY • THE AMERICAS HEADQUARTERS • Chicago, IL USA • 847.843.7900 • 800.556.6766 • www.omron247.com

OMRON CANADA, INC. • HEAD OFFICE

Toronto, ON, Canada • 416.286.6465 • 866.986.6766 • www.omron247.com

OMRON ELECTRONICS DE MEXICO • HEAD OFFICE

México DF • 52.55.59.01.43.00 • 01-800-226-6766 • mela@omron.com

OMRON ELECTRONICS DE MEXICO • SALES OFFICE

Apodaca, N.L. • 52.81.11.56.99.20 • 01-800-226-6766 • mela@omron.com

OMRON ELETRÔNICA DO BRASIL LTDA • HEAD OFFICE

São Paulo, SP, Brasil • 55.11.2101.6300 • www.omron.com.br

OMRON ARGENTINA • SALES OFFICE

Cono Sur • 54.11.4783.5300

OMRON CHILE • SALES OFFICE

Santiago • 56.9.9917.3920

OTHER OMRON LATIN AMERICA SALES

54.11.4783.5300

OMRON EUROPE B.V. • Wegalaan 67-69, NL-2132 JD, Hoofddorp, The Netherlands. • +31 (0) 23 568 13 00 • www.industrial.omron.eu

Authorized Distributor:

Automation Control Systems

- Machine Automation Controllers (MAC) • Programmable Controllers (PLC)
- Operator interfaces (HMI) • Distributed I/O • Software

Drives & Motion Controls

- Servo & AC Drives • Motion Controllers & Encoders

Temperature & Process Controllers

- Single and Multi-loop Controllers

Sensors & Vision

- Proximity Sensors • Photoelectric Sensors • Fiber-Optic Sensors
- Amplified Photomicrosensors • Measurement Sensors
- Ultrasonic Sensors • Vision Sensors

Industrial Components

- RFID/Code Readers • Relays • Pushbuttons & Indicators
- Limit and Basic Switches • Timers • Counters • Metering Devices
- Power Supplies

Safety

- Laser Scanners • Safety Mats • Edges and Bumpers • Programmable Safety Controllers • Light Curtains • Safety Relays • Safety Interlock Switches