



Schroff[®]

DESIGN GUIDE

ELECTRO-MECHANICAL STANDARDS

Introduction to the Standards Summary

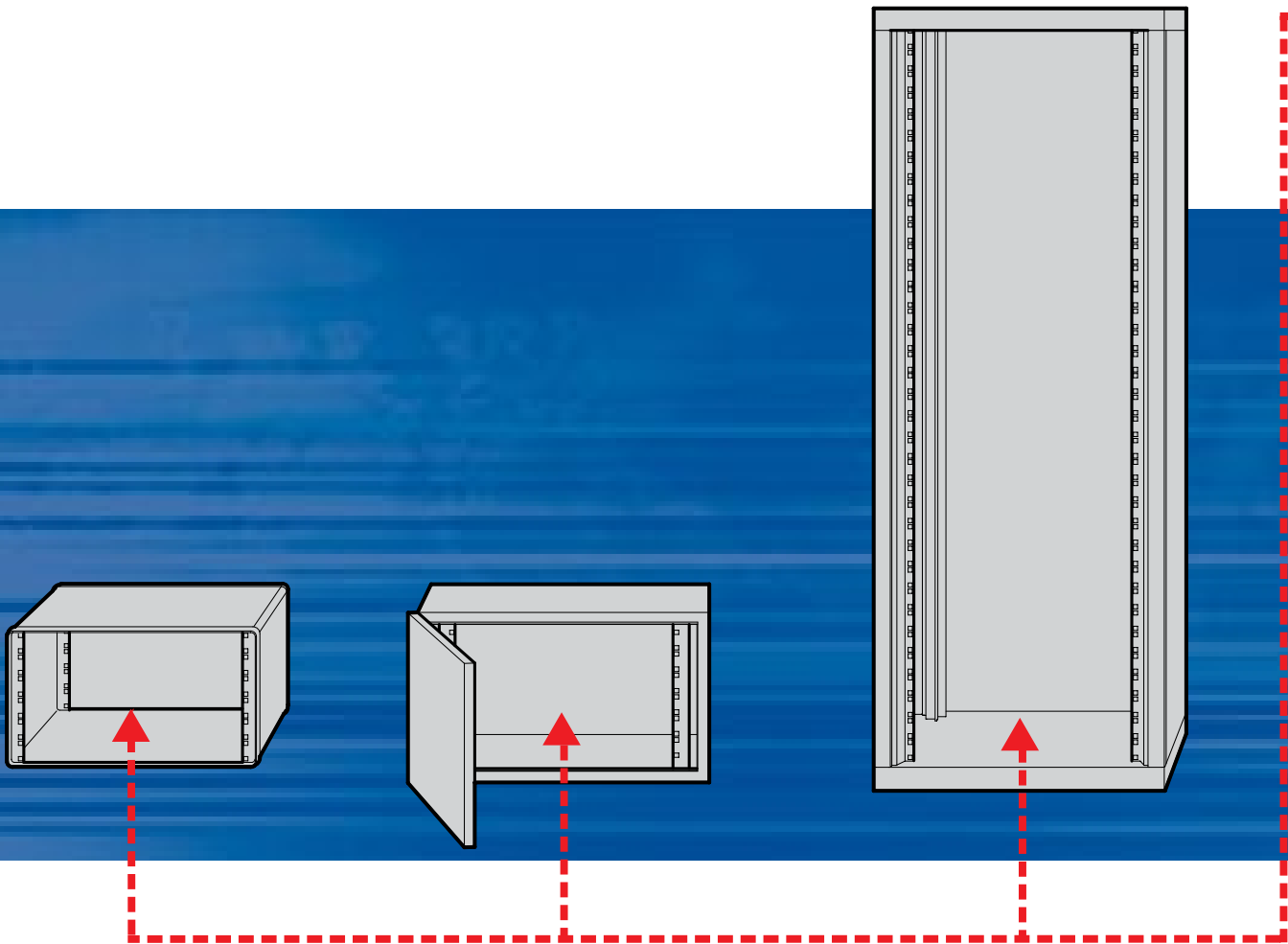

Why is Pentair Technical Products' Schroff® brand committed to standards and modular concepts?

Commercial electronic devices are investments with relatively long life cycles, where high reliability and availability are predominant requirements. In order to keep the cost low and, at the same time, maintain a very high quality level, standard designs with predefined performance levels are indispensable. Subracks, cases and cabinets are structural parts of any equipment. The standards philosophy allows short development time and fast market introduction for these products without expensive development, testing and validation procedures.

Are standard product platforms as flexible and cost-effective as proprietary designs?

If a product with relatively high quantities and a long, steady lifecycle is demanded, most likely a proprietary design will be favorable. But for most electronics markets, the required investments are too high for proprietary designs; if we consider all development and sourcing costs realistically. Standard product platforms typically consist of a modular concept which provides a wide variety of off-the-shelf products.

Contents of the standards summary

This standards summary is the latest release with updated contents. The purpose of this document is to inform designers and project engineers about the most important mechanical standards of the globally developed and approved IEC standards in a very condensed manner. Users are encouraged to look up more detailed information on IEC's website or in other printed sources.

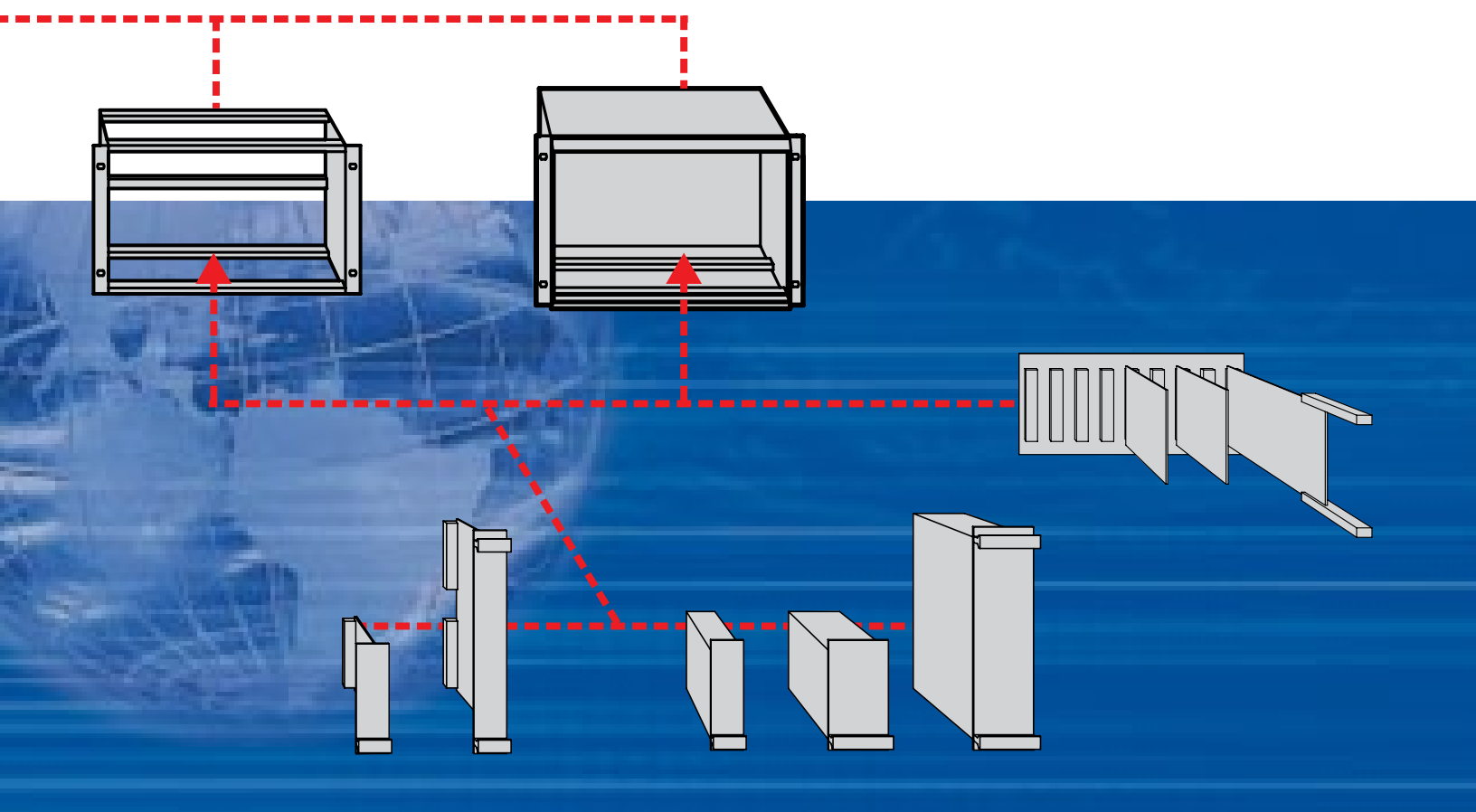

The Schroff® commitment to standards

Since 1978 Schroff® is actively participating in the standardization of “Mechanical Structures for Electronics Equipment” in the global IEC organization. As an international company with global customers we feel responsible for the progress in standardization by implementing the latest technologies and converting them into standard product platforms.

Members of the Schroff Group are working closely to the most innovative markets where the requirements are emerging and are developing answers within the global Schroff team of experts. That is the way we work in both directions: Listen to the local markets and develop global concepts with a strategic view.

Standardization Summary - a Guide Through International Standards for Electronics Packaging

IEC standards

The globalization of the commercial electronics market creates a demand for internationally valid standards. Time-to-market and development expenses of an electronic device force application engineers to use off-the-shelf products rather than design proprietary packaging solutions. Recently developed Electronics Packaging standards comprise dimensional specifications and – on a higher level – the criteria for physical integrity, electromagnetic compatibility and thermal management.

With regard to such comprehensive market requirements, the technical subcommittee 48D of the International Electrotechnical Commission (IEC) created a whole new series of standards.

Dimensional Compatibility	Physical Integrity	Seismic Durability	Electromagnetic Compatibility	Thermal Management
IEC 60297-1	IEC 61587-1	IEC 61587-2	IEC 61587-3	IEC 62194, Ed.1
IEC 60297-2	IEC 61969-3			
IEC 60297-3-101				
IEC 60297-3-102				
IEC 60297-3-103				
IEC 61969-2-1				
IEC 61969-2-2				
IEC 60917-2-X				

VME, CPCI and ATCA

In addition to IEC standards there are application specifications created by specific market user groups. Examples are VME, created by VITA (VME International Trade Association) or CPCI and ATCA, created by PICMG (PCI-International Computer Manufacturing Group). Details of VME and CPCI have been incorporated into the latest IEC standards (IEC 60297-3-101 up to -103) which opens new features for the general use in other applications. ATCA (Advanced Telecommunication Computing Architecture) represents the implementation of an 8 U Eurocard form factor into a 19", resp. a 23" wide chassis. Board level products of ATCA will not fit into IEC standardized subracks due to deviating dimensional details.

ETS standards

ETS standards have been created by ETSI (European Telecommunication Standardization Institute) for the European Telecommunication installations. ETS standards are closely related to IEC standards with specific focus on telecom requirements. While the cited IEC standards in the table above deal with the structural properties of the equipment design, the ETS is also specifying the working conditions.

Scope of the standards summary

This standardization summary will present the main contents of the relevant standards with the intention to create better understanding of the correlations and application aspects. For the full contents, the IEC website will provide all necessary information.

Mechanical Structures for Electronics Equipment

1.00	6
1.00 Design guide for subracks and associated plug-in units	6
1.01 Overview of the 482.6 mm (19") standard series, IEC 60297-3-101	7
1.02 Basic subrack dimensions	8
1.03 Guide rail dimensions	9
1.04 Printed boards	10
1.05 Connectors and backplanes	11
1.06 Subrack depth mounting dimensions	12
1.07 Subrack front mounting dimensions	13
1.08 Dimensions of subrack associated plug-in units	14
1.09 Subrack/front panel shielding interface dimensions	15
1.10 Subrack/plug-in unit electrostatic discharge provisions (ESD)	16
1.11 Subrack/plug-in unit keying and alignment pin	17
2.00	18
2.00 Design guide for indoor cabinets	18
2.01 Cabinet dimensions for the 482.6 mm (19") standard series, IEC 60297-2	19
2.02 Cabinet dimensions for ETS 300 119-3 (European Telecom Standards)	20
2.03 Cabinet dimensions for the 25 mm standard series, IEC 60917-2-1	21
3.00	22
3.00 Outdoor enclosures	22
4.00	23
4.00 Retainers	23-25
5.00	26
5.00 Climatic and physical tests for subracks and cabinets in accordance to IEC 61587-1, -2, -3	26
5.01 Climatic tests	27
5.02 Static load and dynamic tests for subracks and cabinets in accordance to IEC 61587-1	28
5.03 Environmental requirements for outdoor enclosures in accordance to IEC 61969-3	29
5.04 Seismic tests in accordance to IEC 61587-2	29
6.00	30
6.00 Electromagnetic shielding performance tests	30
7.00	31
7.01 Safety requirements and Safety requirements, IEC 60950	31
7.02 IP degrees of protection	32
8.00	33
8.00 Thermal management	33
9.00	34
9.00 VME and CPCI	34
10.00	34
10.00 Advanced TCA - PICMG 3.0	34

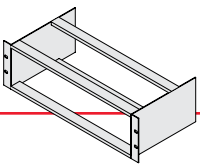

1.00 Design Guide for subracks and associated plug-in units

1.00



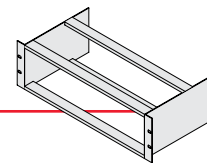

1.01 Overview of the 482.6 mm (19") standard series IEC 60297-3-101

Figure 1

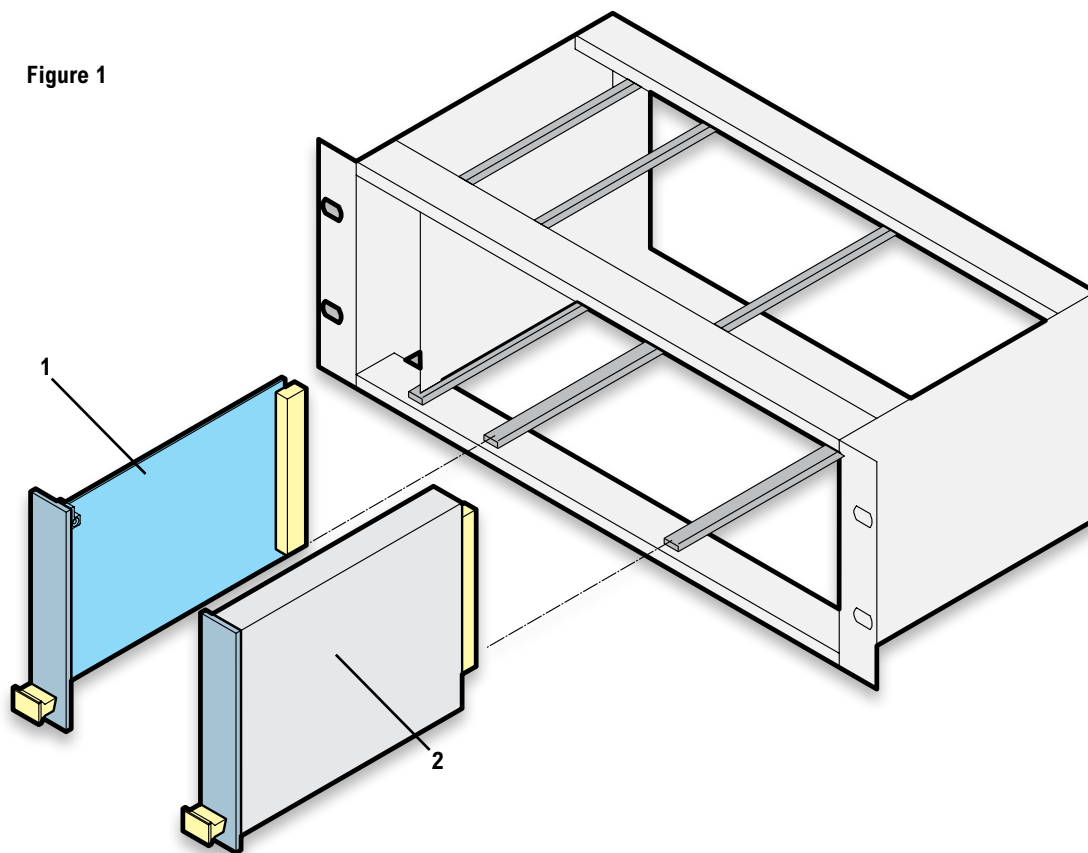

- 1 Board type plug-in unit
- 2 Box type plug-in unit

19" system dimensions and definitions

The width over the mounting flanges is 482.6 mm (19"), which created the term **19" system**.

Width

The overall width behind the mounting flanges (incl. screws) shall be max. 449 mm. The subrack aperture width is subdivided by a modular pitch of 1 **HP** = 5.08 mm (2/10").

Height

The subrack total height is defined by a multiple of a unit of 1 U = 44.45 mm (1 3/4").

Depth

The subrack total depth is not explicitly specified by the standard. The individual dimensions depend on the board depth, rear connector tails or rear input/output plug-in units.

A **slot** is a multiple of horizontal pitches and may be different in specific applications.

A **board type plug-in unit** consists of a printed board fitted with a front panel and a connector. The subrack aperture dimensions on the front are mirrored to the rear in case of rear-mounted plug-in units.

A **box type plug-in unit** is typically housing bulky components or multiples of boards.

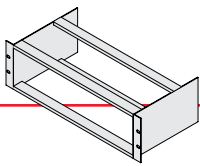

1.02 Basic subrack dimensions

Figure 2a

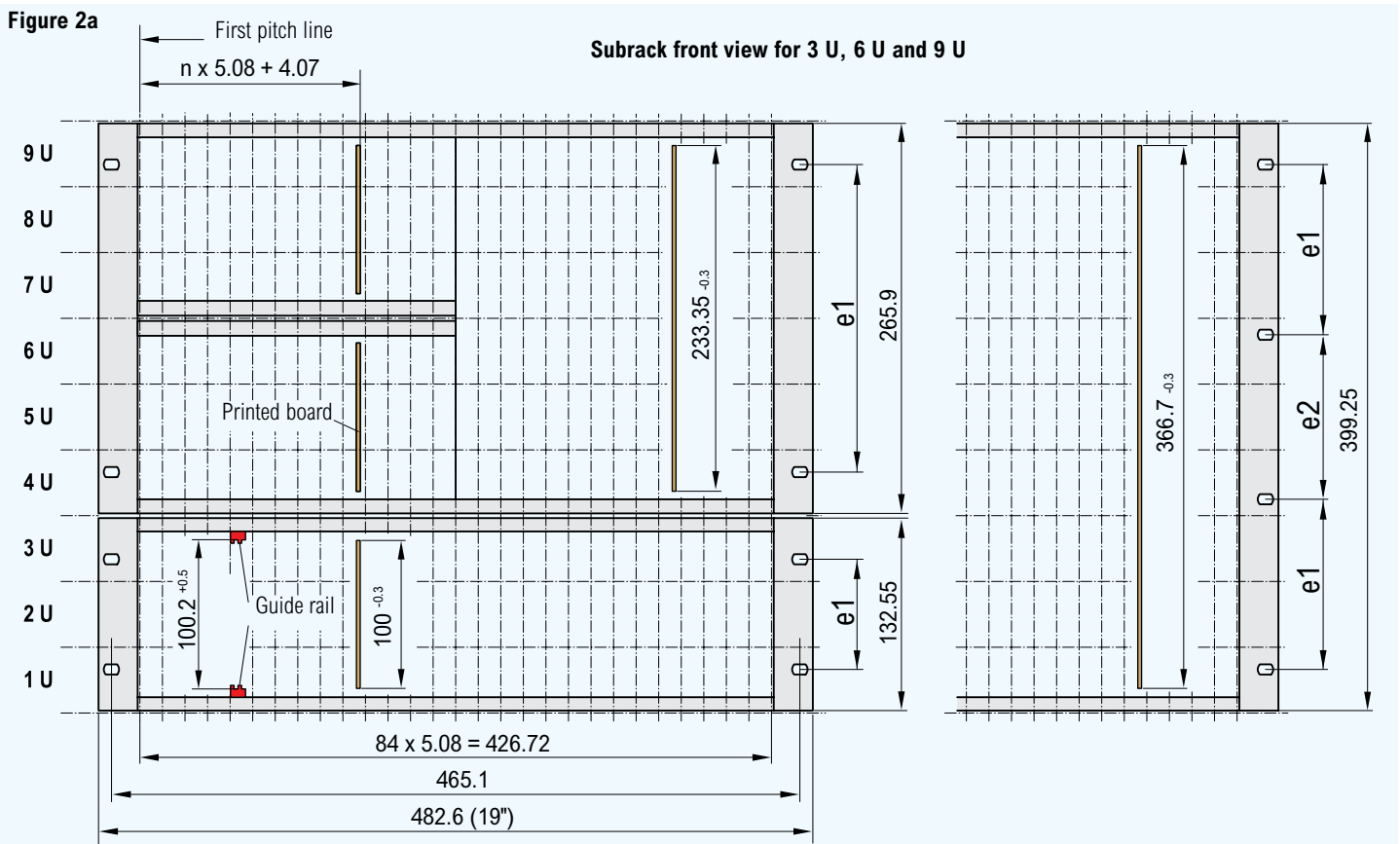

Height

1 U = 44.45 mm. Nominal: $(44.45 - 0.8) \pm 0.4$
 3 U = $(3 \times 44.45 - 0.8) \pm 0.4 = 132.55 \pm 0.4$

Width

482.6 mm ± 0.4
 Mounting grid for front panels: 5.08 mm
 Subrack aperture: $> 84 \times 5.08$ mm

Note

The height dimension 100.2^{+0.5} mm is derived from the printed board height dimension and a min. tolerance of 0.2 mm. The max. tolerance of $0.2 + 0.5 = 0.7$ mm includes the clearance tolerance of the subrack horizontal members.

Figure 2b

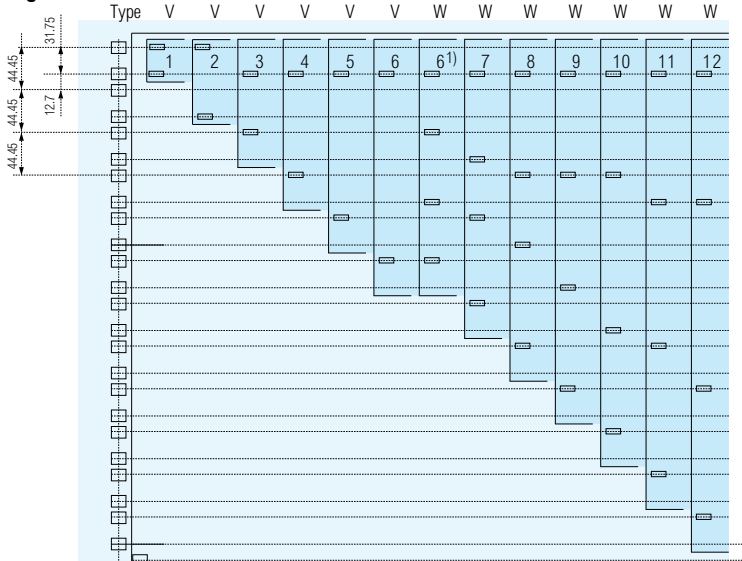

¹⁾ optional design

Figure 2c

Dimensions and description of front panel height arrangements				
Size	Type	Height	e1	e2
1	V	43.65	31.75	—
2	V	88.1	76.2	—
3	V	132.55	57.15	—
4	V	177.0	101.6	—
5	V	221.45	146.05	—
6	V	265.9	190.5	—
6 ¹⁾	W	265.9	76.2	57.15
7	W	310.35	57.15	88.9
8	W	354.8	76.2	101.6
9	W	399.25	120.65	101.6
10	W	443.7	165.1	101.6
11	W	488.15	146.05	133.35
12	W	532.6	190.5	133.35

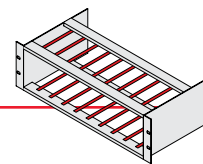

1.03 Guide rail dimensions

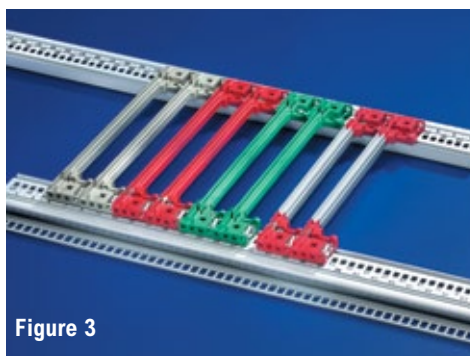
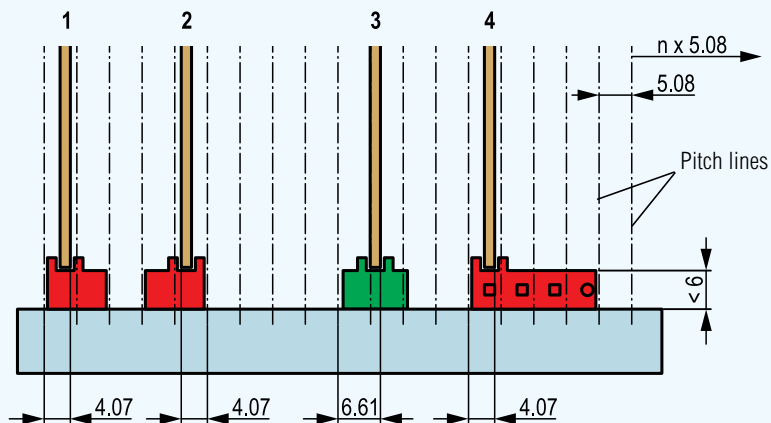

Figure 3

Printed board thickness is in general 1.6 mm. Thicker boards are possible but need to be agreed between contracting parties. If two part connectors are used the increased thickness shall be opposite to the reference plane of the board (Ref. plane = ref. to first pitch line).

Figure 4



- 1 Guide rail for plug-in units as per IEC 60297-3-101
- 2 Mirrored to version 1. Used for rear I/O or on right hand position
- 3 Guide rail with off-set position (board shifted by 2.54 mm)
- 4 Guide rail with keying and alignment pin receptacle as per IEC 60297-3-103 (see also 1.11)

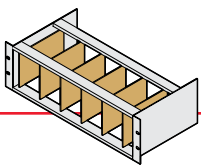

1.04 Printed boards

Figure 5

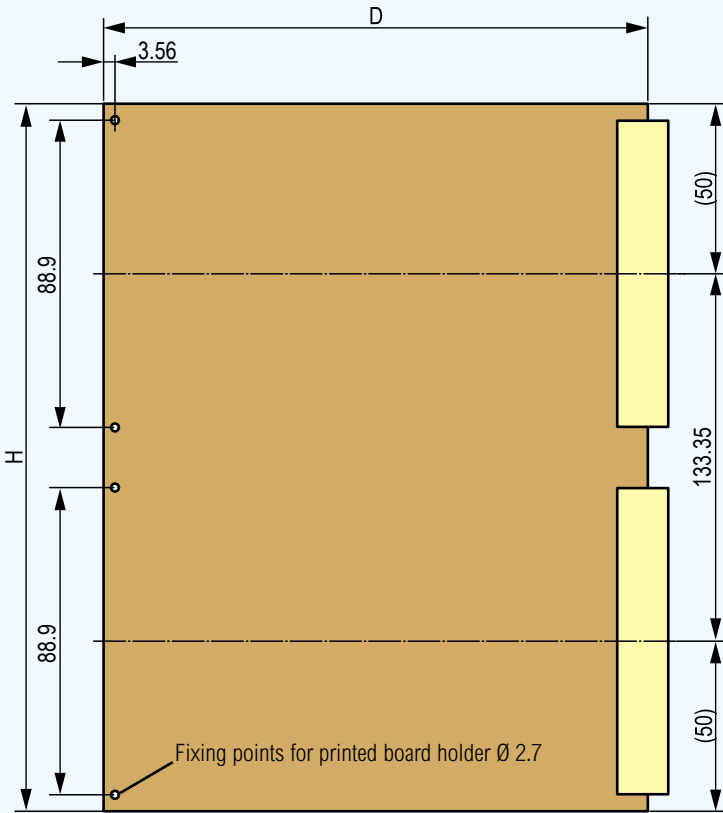

The printed board dimensions are specified in IEC 60297-3-101. The figure below shows a typical 6 U board.

Dimensions

The printed board dimensions are defined as the base of the Eurocard form factor ($H = 100 \times D = 160 \text{ mm}$).

Height

The height increments are in accordance to the units of the subrack (1 U = 44.45 mm). The table shows the most popular board formats.

Thickness

The thickness of a board is, if nothing specifically required, 1.6 mm. Thicker boards should be agreed between user and vendor with respect to the accessories concerned, e. g. guide rails. IEC 60297-3-101 as the relevant standard for 19" based subracks deals with two part connectors of the series IEC 60603-2, IEC 61076-4-113 and IEC 61076-4-101. Other connectors may influence the board or subrack depth dimensions.

Table 1

Printed board	
Height H +0/-0.3	Depth D +0/-0.3
	80
3 U = 100	100
6 U = 233.35	160
9 U = 366.7	220
	280

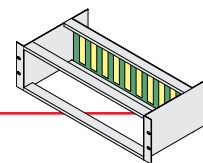

1.05 Connectors and backplanes

Figure 6

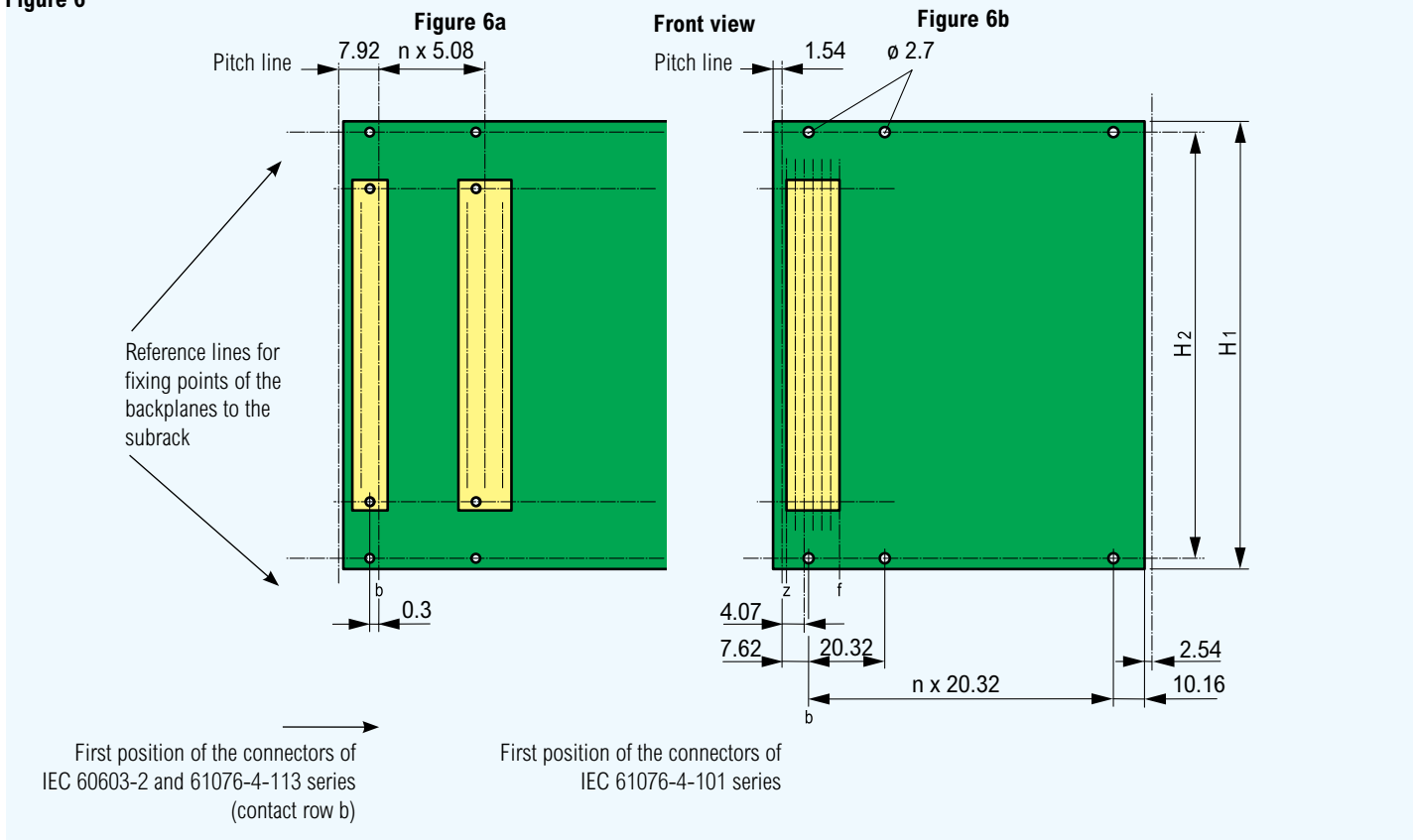

The connectors of the above described IEC series fit on the backplane within the same slot width but with different reference dimensions of the contact grids to the pitch line. The contact grid in figure 6a is 2.54 mm and 2 mm in figure 6b.

Typical applications for the IEC 60603-2 and IEC 61076-4-113 series are VME64 and VME64x. IEC 61076-4-101 series connectors are used for Compact PCI.

The formula for $H_1 = n \times U - 4.8$
 Example for 3 U = $3 \times 44.45 - 4.8 = 128.55$

The formula for
 $H_2 = n \times U - 10.85 = 3 \times 44.45 - 10.85 = 122.5$

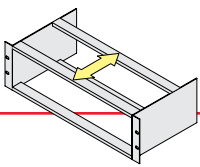

1.06 Subrack depth mounting dimensions

Inspection dimensions for the subrack front depth D from the front attachment plane to the backplane attachment plane

The formula for connectors type IEC 60603-2 and 61076-4-113 (application example VME) is the same as for connectors type IEC 61076-4-101 (application example CPCI):

$D = \text{printed board depth} + 15.6$
(e. g. $160 + 15.6 = 175.6$).

Figure 7

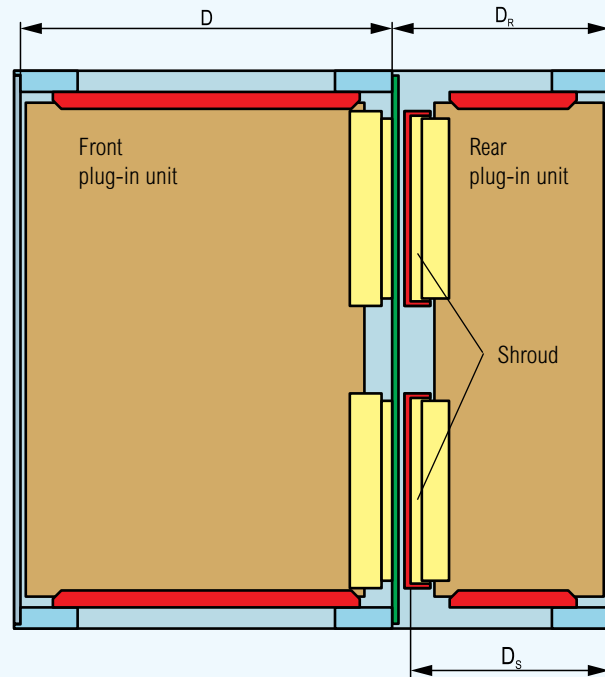

Inspection dimensions for the subrack rear depth D_R from the rear attachment plane to the backplane attachment plane

Application example VME

The formula for connectors type IEC 60603-2 and 61076-4-113 is:

$D_R = \text{printed board depth} + 22.48$
(e. g. $80 + 22.48 = 102.48$).

Application example CPCI

The formula for connectors type IEC 61076-4-101 is:

$D_R = \text{printed board depth} + 20$
(e. g. $80 + 20 = 100$).

Explanations for the rear arrangement of plug-in units

For I/O interface the rear plug-in units are fitted with the inverted versions of the connector types. This allows the plug-in function to be directly on the tails of the front connectors protruding from the backplane. The shroud is used as a mechanical support to align the rear plug-in function and to protect the tails from damage.

Inspection dimensions for the shroud D_S from the rear attachment plane to the bottom of the shroud

Application example VME

The formula for connectors on the rear plug-in unit type IEC 60603-2 (inverted version) is:

$D_S = \text{printed board depth} + 10.28$
(e. g. $80 + 10.28 = 90.28$).

Application example VME 64 extension

The formula for connectors type IEC 61076-4-113 is:

$D_S = \text{printed board depth} + 12.78$

Application example CPCI

The formula for connectors type IEC 61076-4-101 is:

$D_S = \text{printed board depth} + 12.14$

The max. thickness of the backplane should not exceed 6 mm.

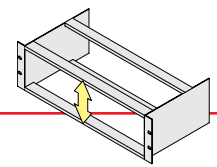

1.07 Subrack front mounting dimensions

Figure 8

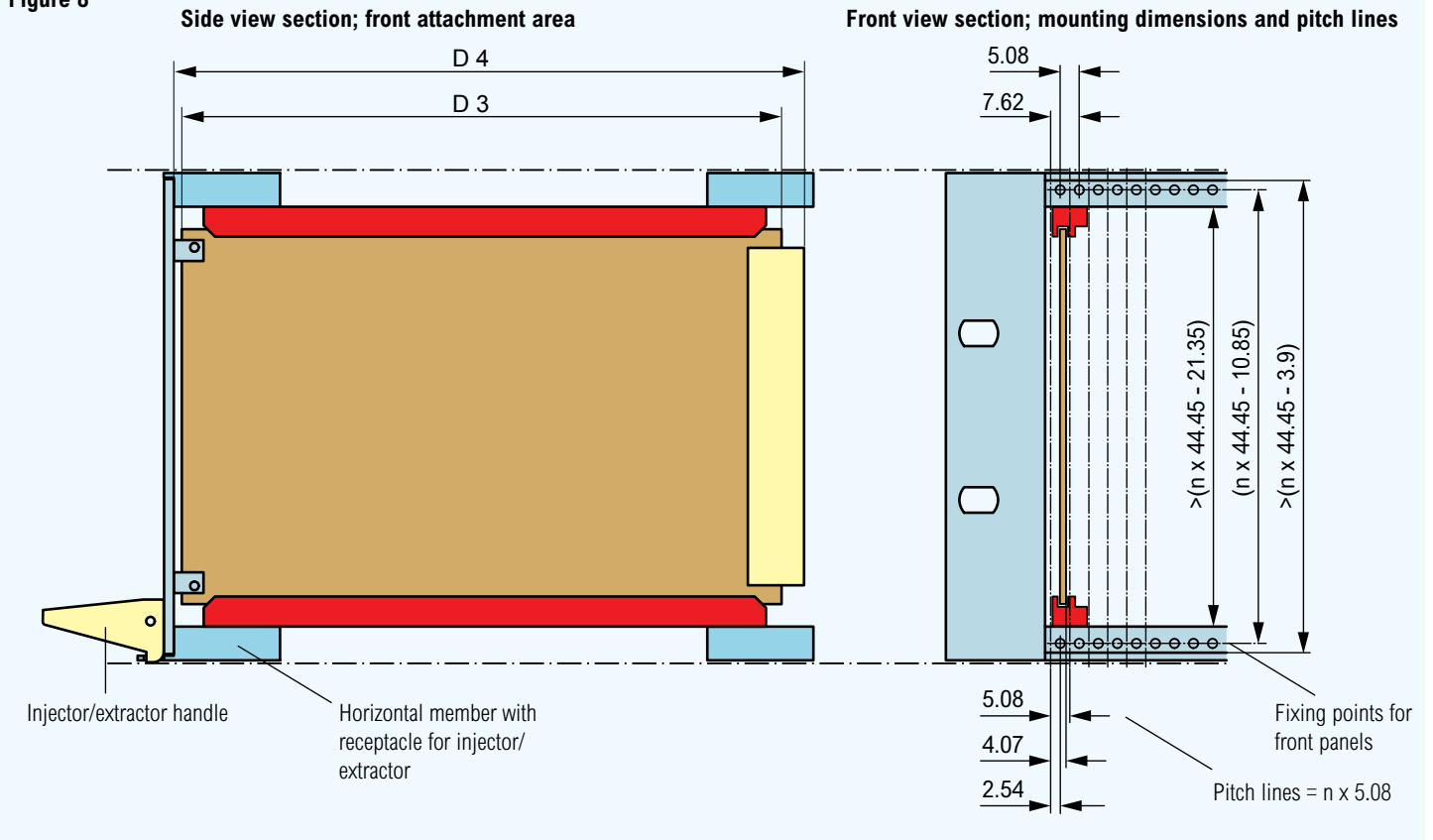

Subrack front design alternatives

For the subrack front design two options are applicable: Horizontal members with or without injector/extractor receptacle.

For details see IEC 60297-3-101 and IEC 60297-3-102.

Table 2

Inspection dimensions for plug-in units				
D 3 - 0.3 1)	80.00	160.00	220.00	280.00
D 4 ± 0.4 2)	89.93	169.93	229.93	289.93
D 4 ± 0.4 3)	91.93	171.93	231.93	291.93
D 4 ± 0.4 4)	91.74	171.74	231.74	291.74

- 1) Printed board depth
- 2) Depth inspection dimension with connector IEC 60603-2, Type B, C, D and IEC 61076-4-113
- 3) Depth inspection dimension with connector IEC 60603-2, Type F, G and H
- 2) Depth inspection dimension with connector IEC 61076-4-101

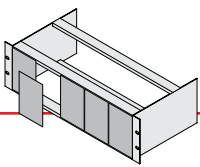

1.08 Dimensions of subrack associated plug-in units

Figure 9

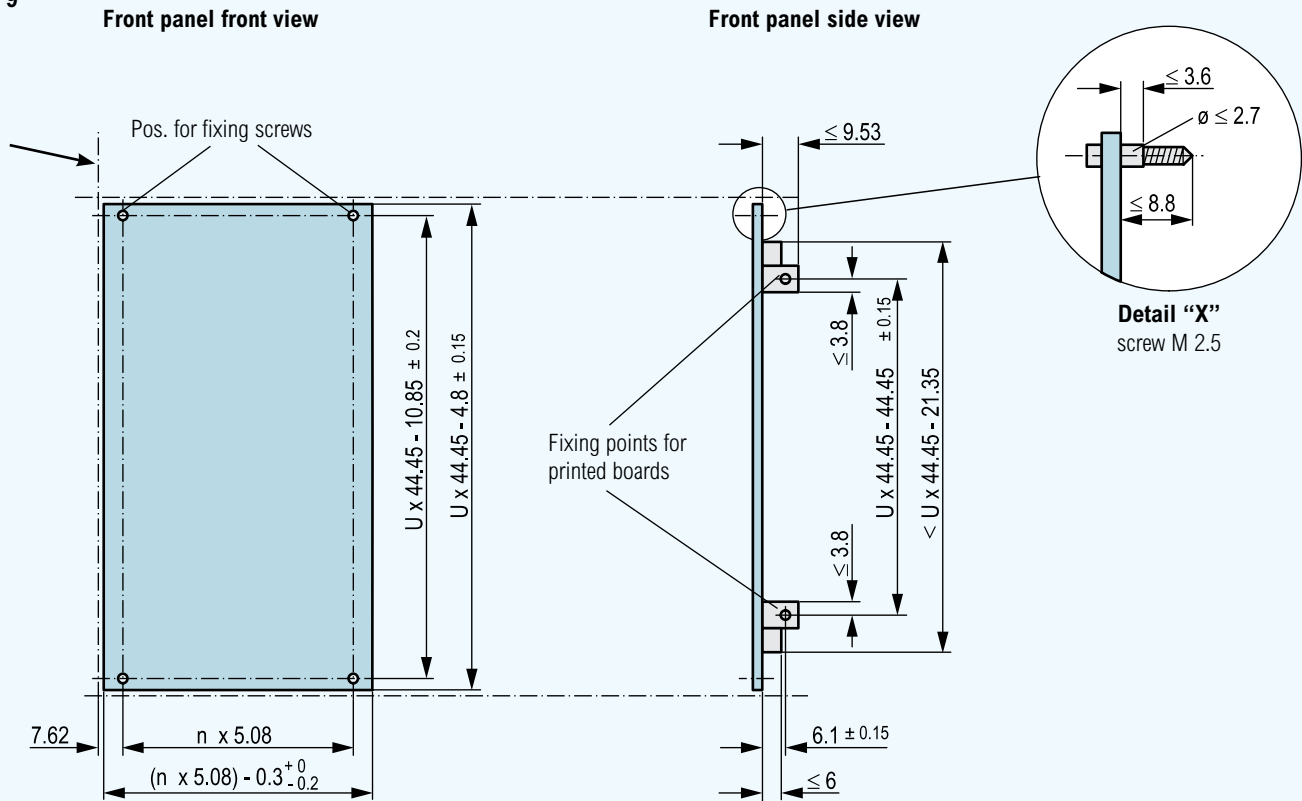

The drawings above illustrate the dimensional rules of the front panels within the pitch lines of a subrack and the reference fixing points for printed boards at the rear of a front panel. Detail "X" is the only standardized fixture but may be replaced by individual fasteners if agreed between vendor and user.

Plug-in units

Subrack related plug-in units are the sub-assemblies of a subrack. There are principally two versions: The printed board type and the box type plug-in units.

The printed board type plug-in unit

consists of a printed board as the carrier of the circuitry and the electronic components including the connector and a front panel.

The box type plug-in unit usually consists of a metal housing in which one or more printed boards may be located. The front panel and the connector positioning follows the same dimensional rules as those applying to the printed board type plug-in units.

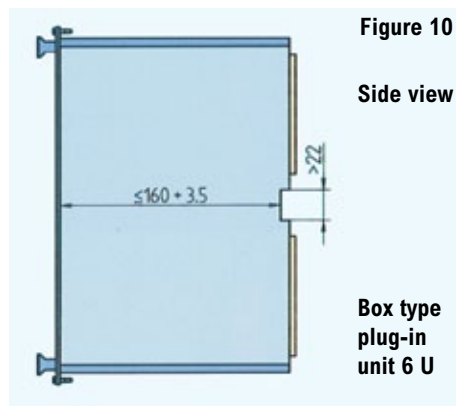
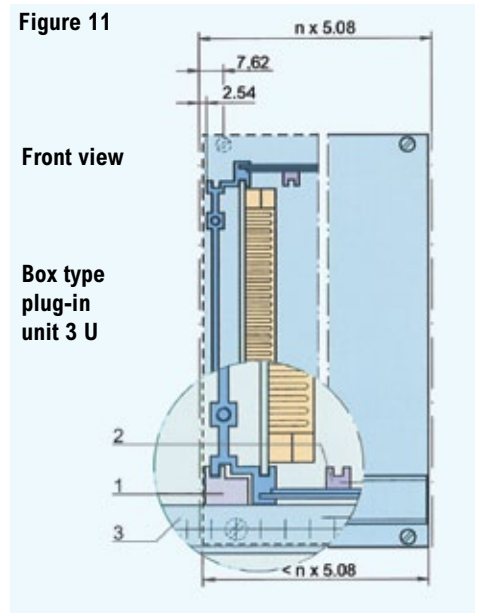
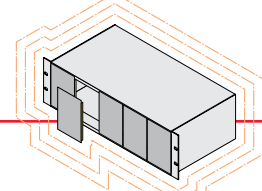

Figure 11



- 1) Guide rail in the subrack
- 2) Guide rail in the frame-type plug-in unit
- 3) Horizontal rail in the subrack



1.09 Subrack/front panel shielding interface dimensions

Figure 12

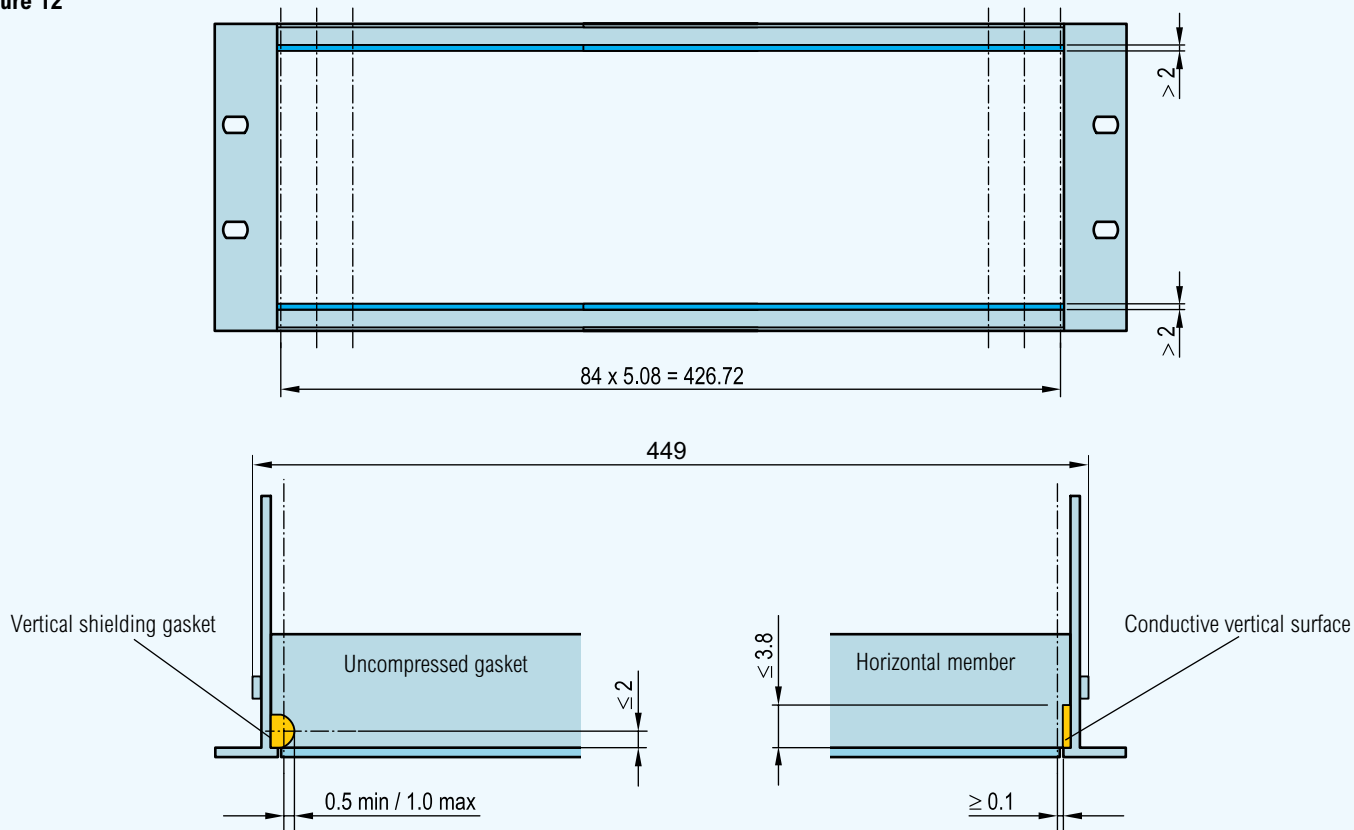
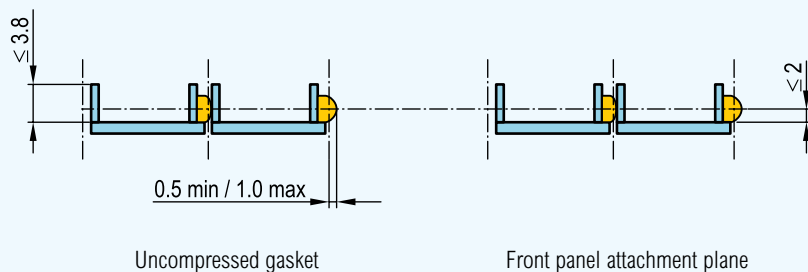

Figure 13

Front panel top view cross section



Subrack/front panel shielding

Shielding measures against high frequency interference are defined by standardized dimensions on the front area only. Other areas of a subrack are not critical regarding the compatibility of plug-in units and are therefore left to individual measures. If rear plug-in units are used the dimensions of the front area should be mirrored.

Missing dimensions see IEC 60297-3-101.

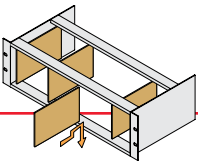

1.10 Subrack/plug-in unit electrostatic discharge provisions (ESD)

Figure 14

Side view cross section: front attachment area

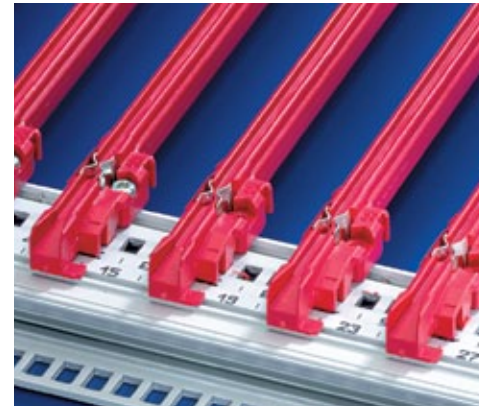
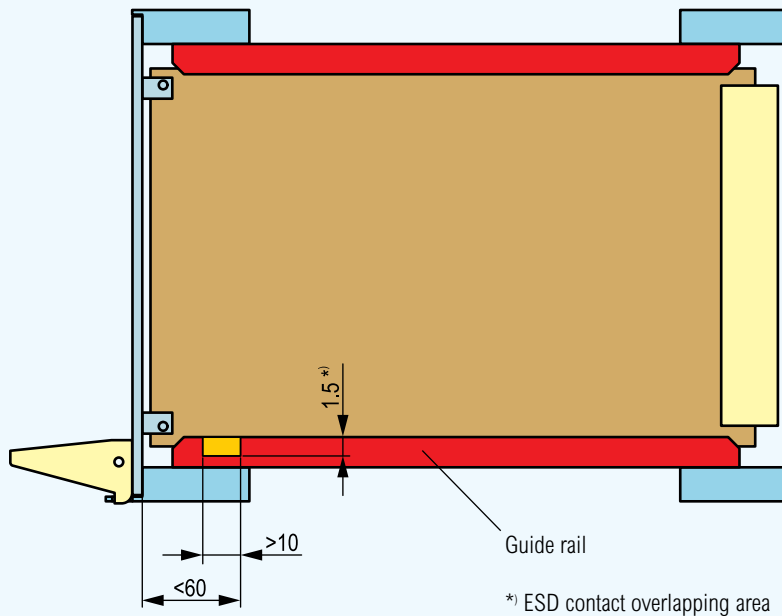

Electrostatic discharge

IEC 60297-3-101 describes an optional method of electrostatic discharge. It is a contact clip which can be placed into the guide rails, close to the front of the subrack. Usually the guide rails are made of insulating material and, if prepared accordingly by the vendor, the same guide rails will mostly accept the ESD clip even when retrofitted.

For the proper function the clip has to connect to grounded parts of the subrack and to conductive sections on the printed board. In order to avoid discharge sparks, a discharge resistor should be used on the printed board.

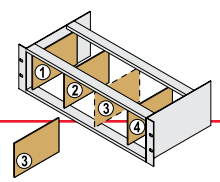

1.11 Subrack/plug-in unit keying and alignment pin

Figure 15

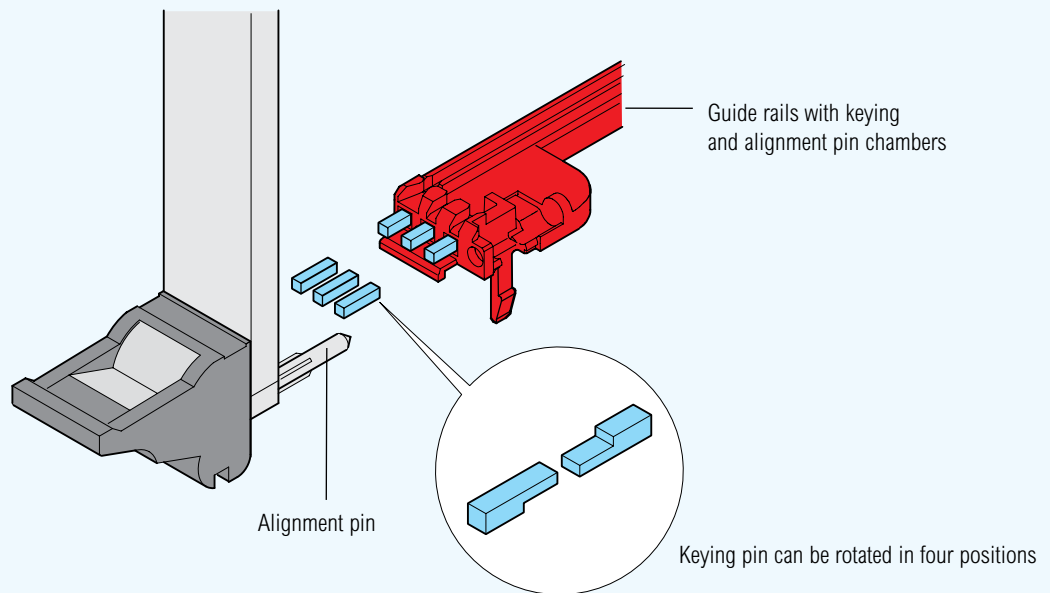

Keying and alignment pin

IEC 60297-3-103 describes an arrangement of keying and alignment between the plug-in unit front panel and the subrack. This method of keying was chosen for the standard instead of connector-related solutions for the benefit of maximum design freedom on the backplane. The alignment pin is designed for the correct positioning of EMC shielded front panels and in specific applications as a discharge pin between the front panel and the subrack. For both solutions, keying and alignment, caution is needed when selecting the subrack and the front panels since retrofitting might become very costly.

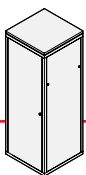

2.00 Design guide for indoor cabinets

2.00



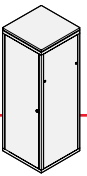

2.01 Cabinet dimensions of the 482.6 mm (19") standards series, IEC 60297-2

Cabinet Dimensions

The cabinet aperture is divided in height units (U) of 44.45 mm. The table of height units (table 3) indicates the minimum usable units with reference to the total height of a cabinet. H 1 includes feet and castors.

The preferred fixing thread should be M 6. Cage nuts may be used by locating into square holes.

The table 4 indicates recommended width and depth dimensions for cabinets.

Figure 18

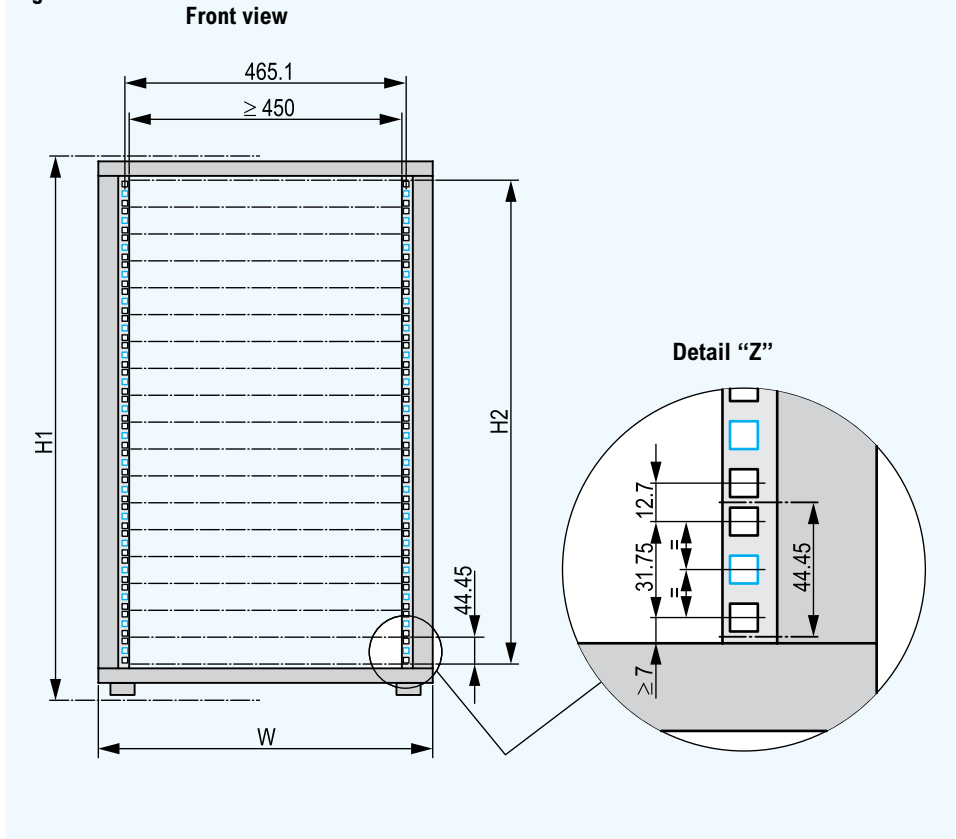

*) Detail "Z" illustrates the pattern of fixing points. The black marked holes are in compliance to the hole pattern of front panels or subracks. The blue marked holes are usable for any other purpose.

Table 3

Height		
H 1 (mm)	H 2 (mm)	Units (U)
800	577.85	13
1000	800.10	18
1200	977.90	22
1400	1200.15	27
1600	1377.95	31
1800	1600.20	36
2000	1778.00	40
2200	2000.25	45

Table 4

Width and Depth	
Width (mm)	Depth (mm)
550	400
600	600
700	800
800	900
900	
Note: the width and depth dimensions may be used in any combination.	

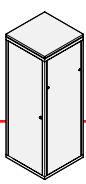

2.02 Cabinet dimensions of ETS 300 119-3 (European Telecom Standards)

Figure 19

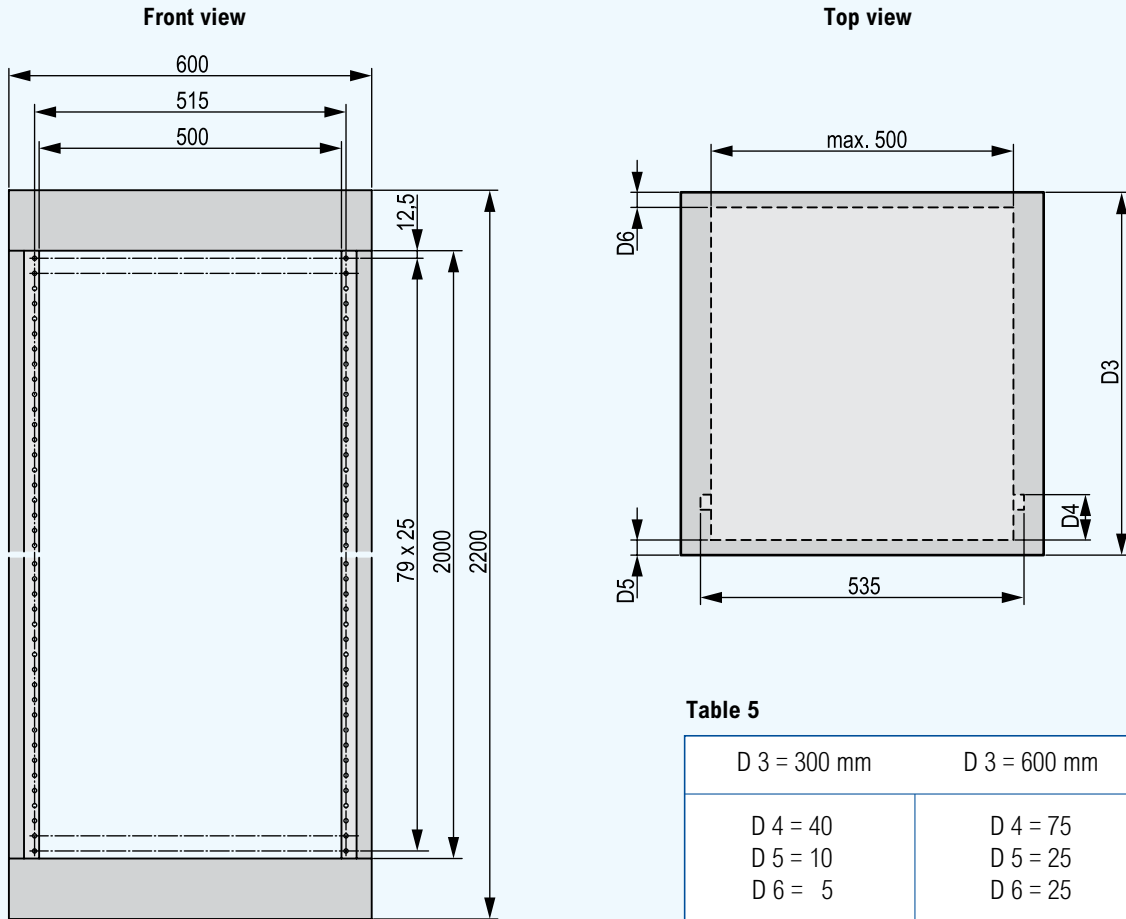
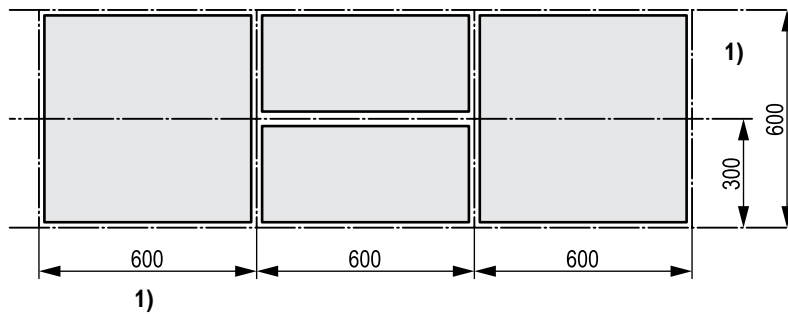
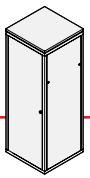

Figure 20

Possible floor arrangement



1) The total width and depth dimensions of the cabinet shall be smaller than the pitch lines in order to fit into the footprint.



2.03 Cabinet dimensions for the 25 mm standard series, IEC 60917-2-1

Cabinet Dimensions

The cabinet aperture height is divided by system units (SU) that are 25 mm high. The table of height units (table 6) indicates the minimum usable inside units with reference to the total outside height of a cabinet. H 1 includes feet and castors.

The table 7 indicates recommended width and depth dimensions for cabinets.

Figure 21

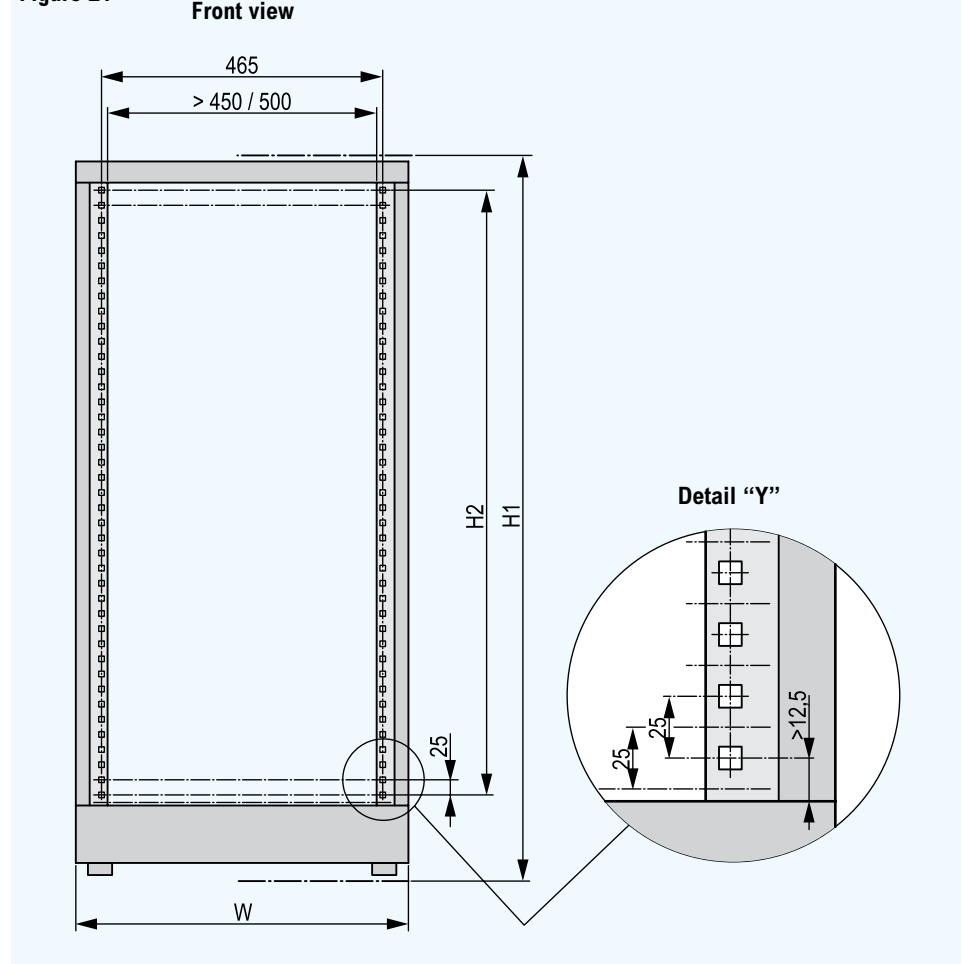

*) Detail “Y” illustrates the pattern of fixing points. The preferred fixing thread should be M 6. Cage nuts may be used by clipping into square holes.

Table 6

Height		
H 1 (mm)	H 2 (mm)	Units (U)
800	550	22
1000	750	30
1200	950	38
1400	1150	46
1600	1350	54
1800	1550	62
2000	1750	70
2200	1950	78

Table 7

Width and Depth	
Width (mm)	Depth (mm)
550	400
600	600
700	800
800	900
900	
Note: the width and depth dimensions may be used in any combination.	

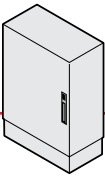

3.00 Outdoor enclosures

3.00



Figure 22

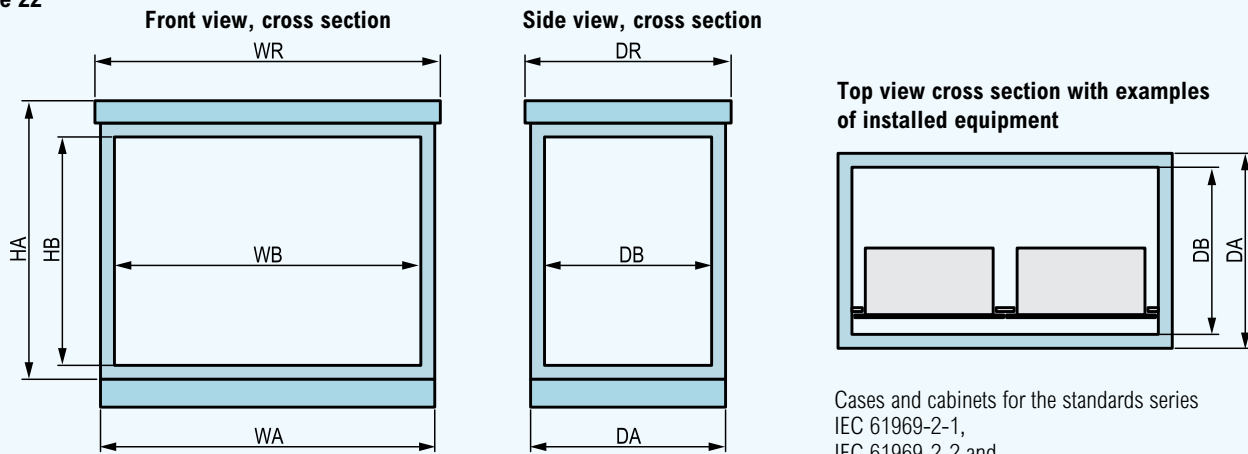

Top view cross section with examples of installed equipment

Cases and cabinets for the standards series IEC 61969-2-1, IEC 61969-2-2 and ETS/ EN 301 169-2.

The dimensions shown in the table are preferred dimensions only, selected from IEC 61969-2-1, IEC 61969-2-2 and ETS / EN 301 169-2. The roof dimensions (WR and DR) may exceed the enclosure by max 25 mm on each side. The dimensions of the plinths are not considered as part of the enclosure and may increase by $n \times 25$ mm. Missing or additional dimensions: see referenced standards.

Table 8

HA	HB	WA	WB	DA	DB
600	400	700	535		
1000	800	900	735	400	300
1200	1000	1300	1135	700	600
1400	1200	1900	1735		
1800	1600				

All dimensions in mm.



CARD-LOK

For cold wall applications
The Card-Lok series of retainers offer the highest locking force available for cold wall applications. They mount to Printed Circuit Board assemblies using screws, rivets or adhesive bonding and are then inserted into machined channels of cold plates or heat exchangers. The wedge design holds the Printed Circuit Board firmly in place providing high resistance to shock and vibration while producing maximum thermal transfer.

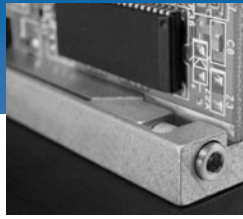

CHANNEL-LOK

For sheet metal or non-machined cold wall applications
The Channel-Lok series of locking retainers are designed for heavy shock and vibration, and for effective heat dissipation in sheet metal chasis/heat sink applications. The design combines chassis mounted housing with Channel-Lok retainers.



METAL RETAINERS

For low cost sheet metal applications or cold wall applications
The metal retainers offer a low cost spring action printed circuit board retention design. They attach to the chassis using screws, rivets or adhesives. Retainers provide protection against shock and vibration and offer excellent grounding characteristics.



PLASTIC CARD GUIDES

For low cost sheet metal applications
Patented plastic guide entry, easy tool-less installation and snap guides available to support low cost sheet metal card cages.

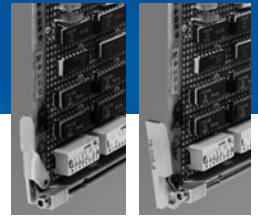

INSERTER & EXTRACTOR

Metal and plastic designs
Calmark offers a wide selection of Injectors and Extractors for use in both sheet metal and cold wall applications. Available in both metal and plastic designs, these products facilitate the insertion and extraction of printed circuit boards with high density backplane interconnects.

Table 1. American National Standard Hexagon and Spline Socket Head Cap Screws (1960 Series) (ANSI B18.3-1982)

Nominal Size	Body Diameter		Head Diameter		Head Height		Spline Socket Size	Hex. Socket Size	Fillet Ext.	Key Engagement	
	Max	Min	Max	Min	Max	Min	Nom	Nom	Max	Min.	
	D		A		H		M	J	F	T	
0	0.0600	0.0568	0.096	0.091	0.060	0.057	0.060	-	0.050	0.007	0.025
1	0.0730	0.0695	0.118	0.112	0.073	0.070	0.072	1/16	0.062	0.007	0.031
2	0.0860	0.0822	0.140	0.134	0.086	0.083	0.096	5/64	0.078	0.008	0.038
3	0.0990	0.0949	0.161	0.154	0.099	0.095	0.096	5/64	0.078	0.008	0.044
4	0.1120	0.1075	0.183	0.176	0.112	0.108	0.111	3/32	0.094	0.009	0.051
5	0.2250	0.1202	0.205	0.198	0.125	0.121	0.111	3/32	0.094	0.010	0.057
6	0.1380	0.1329	0.226	0.218	0.138	0.234	0.133	7/64	0.109	0.010	0.064
8	0.1640	0.2585	0.270	0.262	0.164	0.159	0.168	9/64	0.141	0.012	0.077
10	0.1900	0.1840	0.312	0.303	0.190	0.185	0.183	5/32	0.156	0.014	0.090
1/4	0.2500	0.2435	0.375	0.365	0.250	0.244	0.216	3/16	0.188	0.014	0.120
5/16	0.3125	0.3053	0.469	0.457	0.312	0.306	0.291	1/4	0.250	0.017	0.151
3/8	0.3750	0.3678	0.562	0.550	0.375	0.368	0.372	5/16	0.312	0.020	0.182
7/16	0.4375	0.4294	0.656	0.642	0.438	0.430	0.454	3/8	0.375	0.023	0.213
1/2	0.5000	0.4919	0.750	0.735	0.500	0.492	0.454	3/8	0.375	0.026	0.245
5/8	0.6250	0.6163	0.938	0.921	0.625	0.616	0.595	1/2	0.500	0.032	0.307
3/4	0.7500	0.7406	1.125	1.107	0.750	0.740	0.620	5/8	0.625	0.039	0.370
7/8	0.8750	0.8647	1.312	1.293	0.875	0.864	0.698	3/4	0.750	0.044	0.432
1	1.0000	0.9886	1.500	1.479	1.000	0.988	0.790	3/4	0.750	0.050	0.495
1 1/8	1.1250	1.1086	1.688	1.665	1.125	1.111	—	7/8	0.875	0.055	0.557
1 1/4	1.2500	1.2336	1.875	1.852	1.250	1.236	—	7/8	0.875	0.060	0.620
1 3/8	1.3750	1.3568	2.062	2.038	1.375	1.360	—	1	1.000	0.065	0.682
1 1/2	1.5000	1.4828	2.250	2.224	1.500	1.485	—	1	1.000	0.070	0.745
1 3/4	1.7500	1.7295	2.625	2.597	1.750	1.734	—	1 1/4	1.250	0.080	0.870
2	2.0000	1.9780	3.000	2.970	2.000	1.983	—	1 1/2	1.500	0.090	0.995
2 1/4	2.2500	2.2280	3.375	3.344	2.250	2.232	—	1 3/4	1.750	0.100	1.120
2 1/2	2.5000	2.4762	3.750	3.717	2.500	2.481	—	1 3/4	1.750	0.110	1.245
2 3/4	2.7500	2.7262	4.125	4.090	2.750	2.730	—	2	2.000	0.120	1.370
3	3.0000	2.9762	4.500	4.464	3.000	2.979	—	2 1/4	2.250	0.130	1.495
3 1/4	3.2500	3.2262	4.875	4.837	3.250	3.228	—	2 1/4	2.250	0.140	1.620
3 1/2	3.5000	3.4762	5.250	5.211	3.500	3.478	—	2 3/4	2.750	0.150	1.745
3 3/4	3.7500	3.7262	5.625	5.584	3.750	3.727	—	2 3/4	2.750	0.160	1.870
4	4.0000	3.9762	6.000	5.958	4.000	3.976	—	3	3.000	0.170	1.995

*Key engagement depths are minimum.

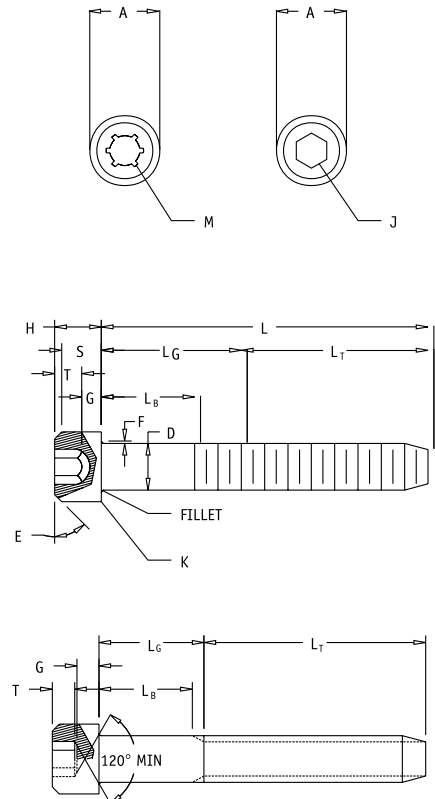

4.00 Retainers

Table 2. American National Standard Hexagon and Spline Socket Flat Counter Head Cap Screws (ANSI B 18.3-1982)

Nominal Size	Body Diameter		Head Diameter		Head Height	Spline Socket Size	Hexagon Socket Size	Key Engagement
			Theoretical Sharp	Absolute Minimum				
	Max	Min	Max	Abs. Min	Reference	Nom.	Nom.	Min.
	D		A		H	M	J	T
0	0.0600	0.0568	0.138	0.117	0.044	0.048	0.035	0.025
1	0.0730	0.0695	0.168	0.143	0.054	0.060	0.050	0.031
2	0.0860	0.0822	0.197	0.168	0.064	0.060	0.050	0.038
3	0.0990	0.0949	0.226	0.193	0.073	0.072	1/16	0.044
4	0.1120	0.1075	0.255	0.218	0.083	0.072	1/16	0.055
5	0.1250	0.1202	0.281	0.240	0.090	0.096	5/64	0.061
6	0.1380	0.1329	0.307	0.263	0.097	0.096	5/64	0.066
8	0.1640	0.1585	0.359	0.311	0.112	0.111	3/32	0.076
10	0.1900	0.1840	0.411	0.359	0.127	0.145	1/8	0.087
1/4	0.2500	0.2435	0.531	0.480	0.161	0.181	5/32	0.111
5/16	0.3125	0.3053	0.656	0.600	0.198	0.216	3/16	0.135
3/8	0.3750	0.3678	0.781	0.720	0.234	0.251	7/32	0.159
7/16	0.4375	0.4294	0.844	0.781	0.234	0.291	1/4	0.159
1/2	0.5000	0.4919	0.938	0.872	0.251	0.372	5/16	0.172
5/8	0.6250	0.6163	1.188	1.112	0.324	0.454	3/8	0.220
3/4	0.7500	0.7406	1.438	1.355	0.396	0.454	1/2	0.220
7/8	0.8750	0.8647	1.688	1.604	0.468	—	9/16	0.248
1	1.0000	0.9886	1.938	1.841	0.540	—	5/8	0.297
1 1/8	1.1250	1.1086	2.188	2.079	0.611	—	3/4	0.325
1 1/4	1.2500	1.2336	2.438	2.316	0.683	—	7/8	0.358
1 3/8	1.3750	1.3568	2.688	2.553	0.755	—	7/8	0.402
1 1/2	1.5000	1.4818	2.938	2.791	0.827	—	1	0.435

All dimensions in inches.

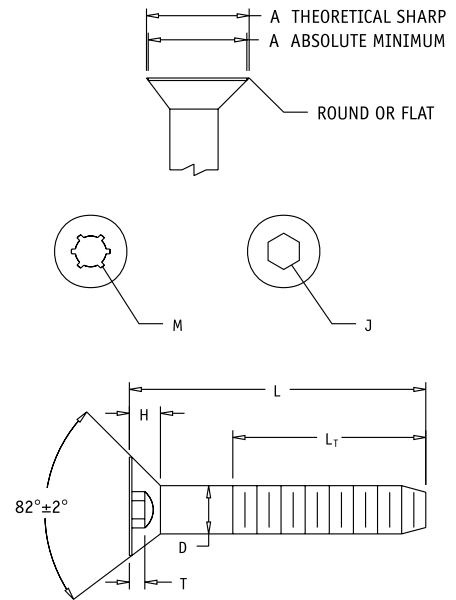
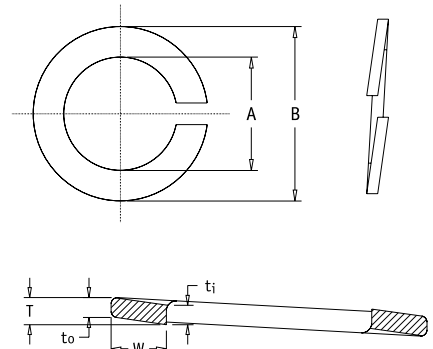

Table 3. American National Standard Helical Spring Washers (ANSI B18.21.1-1972)

Nominal Washer Size	Inside Diameter A		Regular*			Heavy†			Extra Duty‡			
			O.D. # Max	Section Width W	Section Thickness T _s	O.D. # Max	Section Width W	Section Thickness T _s	O.D. # Max	Section Width W	Section Thickness T _s	
	Max	Min	¶	W	T _s	¶	W	T _s	¶	W	T _s	
No. 2	0.086	0.094	0.088	0.172	0.035	0.020	0.182	0.040	0.025	0.208	0.053	0.027
No. 3	0.099	0.107	0.101	0.195	0.040	0.025	0.209	0.047	0.031	0.239	0.062	0.034
No. 4	0.112	0.120	0.114	0.209	0.040	0.025	0.223	0.047	0.031	0.253	0.062	0.034
No. 5	0.125	0.133	0.127	0.236	0.047	0.031	0.252	0.055	0.040	0.300	0.079	0.045
No. 6	0.138	0.148	0.141	0.250	0.047	0.031	0.266	0.055	0.040	0.314	0.079	0.045
No. 8	0.164	0.174	0.167	0.293	0.055	0.040	0.307	0.062	0.047	0.375	0.096	0.057
No. 10	0.190	0.200	0.193	0.334	0.062	0.047	0.350	0.070	0.056	0.434	0.112	0.068
No. 12	0.216	0.227	0.220	0.377	0.070	0.056	0.391	0.077	0.063	0.497	0.130	0.080
1/4	0.250	0.262	0.254	0.489	0.109	0.062	0.491	0.110	0.077	0.535	0.132	0.084
5/16	0.311	0.326	0.317	0.586	0.125	0.078	0.596	0.130	0.097	0.622	0.143	0.108
3/8	0.375	0.390	0.380	0.683	0.141	0.094	0.691	0.145	0.115	0.741	0.170	0.123
7/16	0.438	0.455	0.443	0.779	0.156	0.109	0.787	0.160	0.133	0.839	0.186	0.143
1/2	0.500	0.518	0.506	0.873	0.171	0.125	0.883	0.176	0.151	0.939	0.204	0.162
9/16	0.518	0.582	0.570	0.971	0.188	0.141	0.981	0.193	0.170	1.041	0.223	0.182
0.562	0.625	0.650	0.635	1.079	0.203	0.156	1.093	0.210	0.189	1.157	0.242	0.202
11/16	0.688	0.713	0.698	1.176	0.219	0.172	1.192	0.227	0.207	1.258	0.260	0.221
3/4	0.750	0.775	0.760	1.271	0.234	0.188	1.291	0.244	0.226	1.361	0.279	0.241
3/16	0.812	0.843	0.824	1.367	0.250	0.203	1.391	0.262	0.246	1.463	0.298	0.261
7/8	0.875	0.905	0.887	1.464	0.266	0.219	1.494	0.281	0.266	1.576	0.322	0.285
15/16	0.938	0.970	0.950	1.560	0.281	0.234	1.594	0.298	0.284	1.688	0.345	0.308
1	1.000	1.042	1.017	1.661	0.297	0.250	1.705	0.319	0.306	1.799	0.366	0.330
1 1/16	1.062	1.107	1.080	1.756	0.312	0.266	1.808	0.338	0.326	1.910	0.389	0.352
1 1/8	1.125	1.172	1.144	1.853	0.328	0.281	1.909	0.356	0.345	2.019	0.411	0.375
1 13/16	1.188	1.237	1.208	1.950	0.344	0.297	2.008	0.373	0.364	2.124	0.431	0.396
1 1/4	1.250	1.302	1.271	2.045	0.359	0.312	2.113	0.393	0.384	2.231	0.452	0.417
1 5/16	1.312	1.366	1.334	2.141	0.375	0.328	2.211	0.410	0.403	2.335	0.472	0.438
1 3/8	1.375	1.432	1.398	2.239	0.391	0.344	2.311	0.427	0.422	2.439	0.491	0.458
1 7/16	1.438	1.497	1.462	2.334	0.406	0.359	2.406	0.442	0.440	2.540	0.509	0.478
1 1/2	1.500	1.561	1.525	2.430	0.422	0.375	2.502	0.458	0.458	2.638	0.526	0.496



All dimensions in inches.

* Formerly designated Medium Helical Spring Lock Washers.

† Not recommended for new applications.

‡ Formerly designated Extra Heavy Helical Spring Lock Washers.

¶ The maximum outside diameters specified allow for the commercial tolerances on cold-drawn wire.

T_s mean section thickness - (t₁ + t₂) ÷ 2

Table 4. American National Standard Type A Plain Washers Preferred Sizes
(ANSI B18.22.1-1965, R1975)**

Nominal Washer Size***	Series	Inside Diameter			Outside Diameter			Thickness			
		Tolerance			Tolerance			Basic	Max.	Min.	
		Basic	Plus	Minus	Basic	Plus	Minus				
—	—		0.078	0.000	0.005	0.188	0.000	0.005	0.020	0.025	0.016
—	—		0.094	0.000	0.005	0.250	0.000	0.005	0.020	0.025	0.016
—	—		0.725	0.008	0.005	0.312	0.008	0.005	0.032	0.040	0.025
No. 6	0.138		.0156	0.008	0.005	0.375	0.015	0.005	0.049	0.065	0.036
No. 8	0.164		.0188	0.008	0.005	0.438	0.015	0.005	0.049	0.065	0.036
No. 10	0.190		.0219	0.008	0.005	0.500	0.015	0.005	0.049	0.065	0.036
3/16	0.188		0.250	0.015	0.005	0.562	0.015	0.005	0.049	0.065	0.036
No. 12	0.216		0.250	0.015	0.005	0.562	0.015	0.005	0.065	0.080	0.051
1/4	0.250	N	0.281	0.015	0.005	0.625	0.015	0.005	0.065	0.080	0.051
1/4	0.250	W	0.312	0.015	0.005	0.734*	0.015	0.007	0.065	0.080	0.051
5/16	0.312	N	0.344	0.015	0.005	0.688	0.015	0.007	0.065	0.080	0.051
5/16	0.312	W	0.375	0.015	0.005	0.875	0.030	0.007	0.083	0.104	0.064
3/8	0.375	N	0.406	0.015	0.005	.0812	0.015	0.007	0.065	0.080	0.051
3/8	0.375	W	0.438	0.015	0.005	1.000	0.030	0.007	0.083	0.104	0.064
7/16	0.438	N	0.469	0.015	0.005	0.922	0.015	0.007	0.065	0.080	0.051
7/16	0.438	W	0.500	0.015	0.005	1.250	0.030	0.007	0.083	0.104	0.064
1/2	0.500	N	0.531	0.015	0.005	1.062	0.030	0.007	0.095	0.121	0.074
1/2	0.500	W	0.562	0.015	0.005	1.375	0.030	0.007	0.109	0.132	0.086
9/16	0.562	N	0.594	0.015	0.005	1.156*	0.030	0.007	0.095	0.121	0.074
9/16	0.562	W	0.625	0.015	0.005	1.469*	0.030	0.007	0.109	0.132	0.086
5/8	0.625	N	0.656	0.030	0.007	1.312	0.030	0.007	0.095	0.121	0.074
5/8	0.625	W	0.688	0.030	0.007	1.750	0.030	0.007	0.134	0.160	0.108
3/4	0.750	N	.0812	0.030	0.007	1.469	0.030	0.007	0.134	0.160	0.108
3/4	0.750	W	.0812	0.030	0.007	2.000	0.030	0.007	0.143	0.177	0.122
7/8	0.875	N	.0938	0.030	0.007	1.750	0.030	0.007	0.134	0.160	0.108
7/8	0.875	W	.0938	0.030	0.007	2.250	0.030	0.007	0.165	.0192	0.136
1	1.000	N	1.062	0.030	0.007	2.000	0.030	0.007	0.134	0.160	0.108
1	1.000	W	1.062	0.030	0.007	2.500	0.030	0.007	0.165	0.192	0.136
1 1/8	1.125	N	1.250	0.030	0.007	2.250	0.030	0.007	0.134	0.160	0.108
1 1/8	1.125	W	1.250	0.030	0.007	2.750	0.030	0.007	0.165	0.192	0.136
1 1/4	1.250	N	1.375	0.030	0.007	2.500	0.030	0.007	0.165	0.192	0.136
1 1/4	1.250	W	1.375	0.030	0.007	3.000	0.030	0.007	0.165	0.192	0.136
1 3/8	1.375	N	1.500	0.030	0.007	2.750	0.030	0.007	0.165	0.192	0.136
1 3/8	1.375	W	1.500	0.045	0.010	3.250	0.045	0.010	0.180	0.213	0.153
1 1/2	1.500	N	1.625	0.030	0.007	3.000	0.030	0.007	0.165	0.192	0.136
1 1/2	1.500	W	1.625	0.045	0.010	3.500	0.045	0.010	0.180	0.213	0.153
1 5/8	1.625		1.750	0.045	0.010	3.750	0.045	0.010	0.180	0.213	0.153
1 3/4	1.750		1.875	0.045	0.010	4.000	0.045	0.010	0.180	0.213	0.153
1 7/8	1.875		2.000	0.045	0.010	4.250	0.045	0.010	0.180	0.213	0.153
2	2.000		2.125	0.045	0.010	4.500	0.045	0.010	0.180	0.213	0.153
2 1/4	2.250		2.375	0.045	0.010	4.750	0.045	0.010	0.220	0.248	0.193
2 1/2	2.500		2.625	0.045	0.010	5.000	0.045	0.010	0.238	0.280	0.210
2 3/4	2.750		2.875	0.065	0.010	5.250	0.065	0.010	0.259	0.310	0.228
3	3.000		3.125	0.065	0.010	5.500	0.065	0.010	0.284	0.327	0.249

All dimensions in inches.

*The 0.734-inch, 1.156-inch, and 1.469-inch outside diameters avoid washers which could be used in coin operated devices.

**Preferred sizes are for the most part from series previously designated "Standard Plate" and "SAE." Where common sizes existed in the two series, the SAE size is designated "N" (narrow) and the Standard Plate "W" (wide). These sizes as well as all other sizes of Type A Plain Washers are to be ordered by ID, OD, and thickness dimensions.

***Nominal washer sizes are intended for use with comparable nominal screw or bolt sizes.

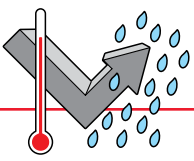

5.00 Climatic and physical tests for subracks and cabinets in accordance to IEC 61587-1, -2, -3

5.00



Subrack electromagnetic shielding performance test



Subrack shock and vibration test

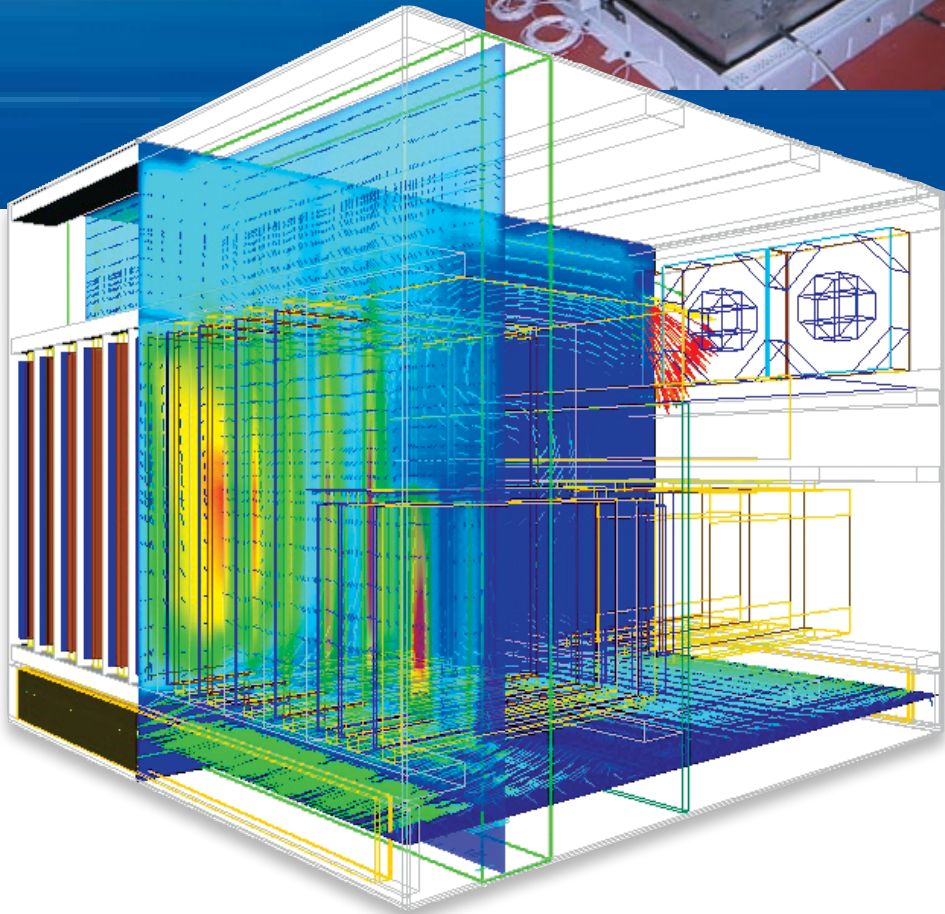

Subrack thermal simulation



The standard IEC 61587 series consists of three parts:

Part 1: Climatic, mechanical tests and safety aspects

Part 2: Seismic tests

Part 3: Electromagnetic shielding performance tests

All tests apply to non-operating equipment in order to support the selection of standard products. The intention of these standards is to set minimum levels of product integrity for the mechanical structure of standard compliant mechanics. By using off-the-shelf products, the specified performance will provide reference values for the individual design requirements. Thus, development risks and leadtime will be significantly reduced.

5.01 Climatic tests

The climatic tests to IEC 61587-1 contain a variety of temperature, humidity and industrial atmosphere tests in indoor and outdoor environments. The tests may be performed statically to check the applied materials or in conjunction with dynamic stress on dummy samples for the assessment of structural parts of an equipment.

Table 9

Performance Level		
1	2	3
Office, laboratory environment -10 °C to +55 °C 20 % to 80 % RH	Production, storage environment -25 °C to +70 °C 20 % to 80 % RH	Outdoor, tropical environment -40 °C to +85 °C 20 % to 95 % RH
Industrial atmosphere Low chemical concentration Sulph. diox. SO ₂ 10 cm ³ /m ³ Hydro. Sulph. H ₂ S 1 cm ³ /m ³	Industrial atmosphere High chemical concentration Sulph. diox. SO ₂ 25 cm ³ /m ³ Hydro. Sulph. H ₂ S 15 cm ³ /m ³	Industrial atmosphere Seaborn, chemical atm. Sulph. diox. SO ₂ 25 cm ³ /m ³ Hydro. Sulph. H ₂ S 15 cm ³ /m ³

RH (relative humidity)

The assessment of test results shall be that no parts have deteriorated in form, fit and function. For complete information about climatic tests, including industrial atmosphere, see IEC 61587-1.

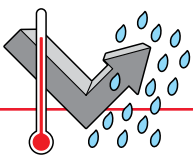

5.02 Static load and dynamic tests for subracks and cabinets in accordance to IEC 61587-1

Subracks

To test the structural stiffness of the subrack it should be mounted into a fixture simulating the mounting conditions in a cabinet.

Figure 23

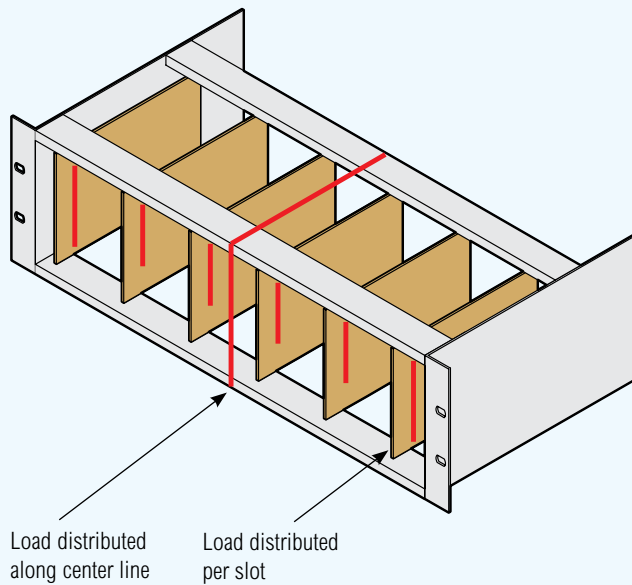

The static load test is intended to check the stiffness of the load bearing parts. The maximum deflection of bottom parts shall not exceed 0.4 mm in order to ensure engagement of the printed boards within the guide rails. The 0.4 mm maximum deflection was defined with regard to the height dimension tolerance of the subrack and the overlap between the guide rails and the printed boards. To check the stiffness the test sample should be loaded with 6 equal dummy boards of 1.15 kg each or one load on the center line and simulated by an applied force of 46 N. The static load test is passed if the deflection of the bottom structural member does not exceed 0.4 mm.

The dynamic test is intended to check typical subracks with shock and vibration as it may occur during normal handling and transportation. The printed boards should be fitted with front panels and bolted to the subrack. To simulate real equipment the printed boards should be fitted with connectors and mating connectors fixed to the rear members of the subrack. The total load of a 3 U subrack should be 3.5 kg and the load of a 6 U subrack should be 7 kg, equally distributed in 14 slots (3 U load per slot = 0.25 kg and 6 U load per slot = 0.5 kg). There are three severity classes of shock and vibration values which may be classified for equipment used under stationary or mobile conditions as well as under extreme dynamic stress (acceleration values of 1 g, 2 g and 5 g). For more details see IEC 61587-1.

Cabinets

The test conditions as specified in IEC 61587-1 are intended to check the cabinet structure for lifting, stiffness and the impact of dynamic stress in respect to three typical fields of application.

Figure 24

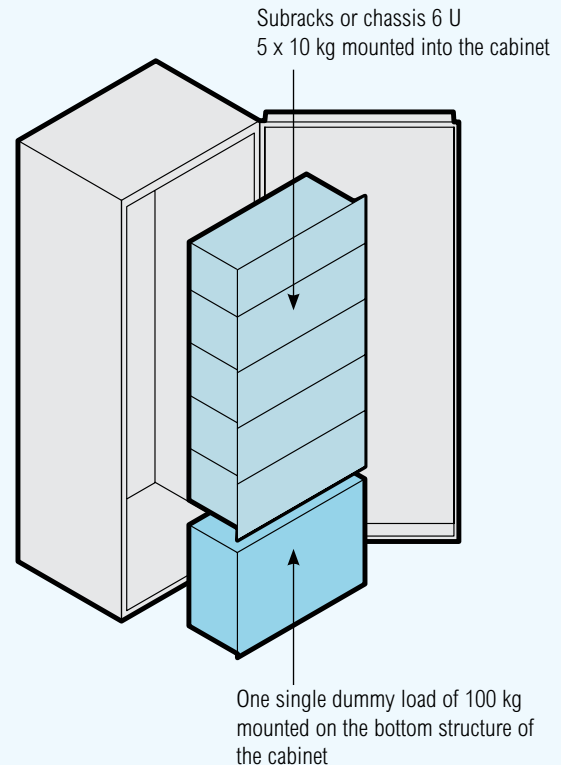

The lifting test should be performed by using a lifting rig applied to the lifting eyes of the cabinet and by fixing the cabinet to the floor. Three severity levels are defined, taking the different cabinet load classes in account: 3000 N, 6000 N and 12000 N applied to the lifting eyes, evenly distributed.

The stiffness test is intended to prove the rigidity of the cabinet structure. For this test the cabinet should be fixed to the floor and side forces of 500 N, 1000 N and 2000 N should be applied to the upper area of the cabinet, within 100 mm under the top edge and along the full depth. This test will be also used as an indicator of the behavior in a seismic test.

The dynamic test is intended to check a dummy loaded cabinet with shock and vibration as it may occur during normal handling and transportation. Three severity levels are specified, simulating stress in typical fields of application (as described for subracks). The tests are passed if no deformation or damage of parts can be detected, affecting fit, form and function.

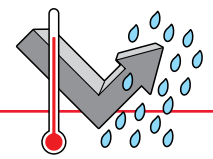

5.03 Environmental requirements for outdoor enclosures in accordance to IEC 61969-3

Electronics/electrical installations in outdoor environments need specific design measures, especially if the place of installation is located in public areas. With this focus, IEC 61969-3 specifies the requirements and tests, in addition to the contents of IEC 61587-1. Climatic test: The values of cold and heat, as well as protection against wind driven rain are chosen in order to simulate harsh environment conditions, e. g. icing. This test concerns

mainly handles, locks, doors and gaskets. The design of those parts shall provide access for maintenance under severe conditions without degradation of the protection levels. Vandalism resistance shall be considered and designed by using heavy latching, locking and hinge parts. For details see IEC 61969-1.



5.04 Seismic tests in accordance to IEC 61587-2

Figure 25

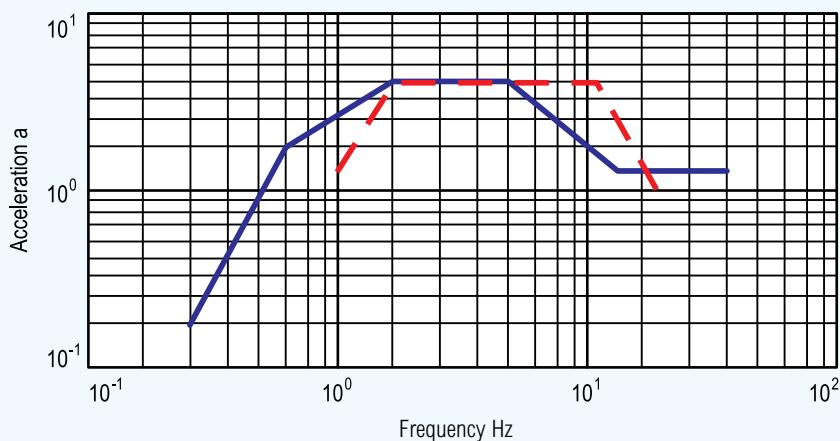

The object of the seismic test is to prove physical integrity represented by a typical set-up, similar to the figure given under 4.02.

There are two severity levels indicating the requirements of different geographic regions: Japan and North America.

The tests are passed if no deformation or damage can be detected affecting fit, form and function.

Japan 

North America 



6.00 Electromagnetic shielding performance tests

EMC is the ability of electrical and electronic equipment to function satisfactorily within its electromagnetic environment, without disturbing or being affected by other equipment in this environment to an acceptable degree.

6.00



Figure 26

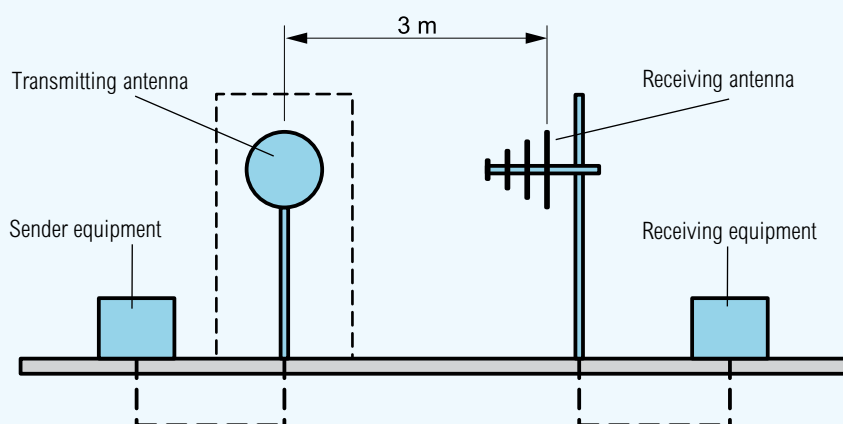

The IEC 61587-3 describes three levels of electromagnetic shielding performance. The specified test conditions and attenuation levels will simplify the selection of enclosures like cabinets and subracks for the user.

Above figure illustrates the set-up for the antennas. The first measurement E1 will be without the enclosure. The next measurement E2 will be made with the transmitting antenna installed inside the enclosure. The difference between the received signal without and with the enclosure represents the shielding effectiveness in dB.

Table 10

Performance Level	30 MHz - 230 MHz	230 MHz - 1000 MHz	1000 MHz - 2000 MHz
1	20 dB	10 dB	0
2	40 dB	30 dB	20 dB
3	60 dB	50 dB	40 dB

Above table reflects the three performance levels with the corresponding attenuation values dependent from the frequency range. Shielding effectiveness $SE = E1 - E2$.



7.00 Safety requirements

7.01 Safety requirements, IEC 60950 IEC 61010



Earthing of removeable parts in a cabinet



Subrack with perforated covers against hazardous voltages. Plastic guide rails self-extinguishing class UL 94 VO.

7.00

Shock hazard voltages

All conductive parts of a mechanical enclosure that can be contacted by hazardous voltage shall be earthed and tested to IEC 61010-1

Mechanical and heat hazards

Mechanical parts of an enclosure system shall be free from sharp edges to prevent injuries. Heat generating components accessible by an operator shall be enclosed or insulated

Fire protection

Design and materials of the enclosure system shall be chosen in order to prevent propagation of fire. Plastic material shall comply with self-extinguishing class V 2 (or better), tested to IEC 60707. Because of the toxic additives contained in materials of higher self-extinguishing classes, ISO 14000 should be regarded. The cover of an enclosure system shall be designed to prevent burning material from dripping into other parts of e. g. a cabinet. IEC 60950 specifies the design requirements for ventilation holes on the bottom part of a cover.



7.02 IP degrees of protection

IEC 60529 specifies the IP degrees of protection of enclosures against dust and water as well as the protection of personnel against dangers inside the enclosure. The IP degrees of protection consist of two digits.

The first digit indicates the protection against foreign bodies (touch with the finger up to dust), the second digit indicates the protection against water.

Table 11

Protection against contact and foreign bodies		
IP 1st digit	Contact	Foreign bodies
0	no protection	no protection
1	with large parts of the body (back of the hands)	large foreign bodies, diameter greater than or equal to 50 mm
2	with a finger	medium-size foreign bodies, diameter greater than or equal to 12 mm
3	with tools and wires, diameter greater than or equal to 2.5 mm	small foreign bodies, diameter greater than or equal to 2.5 mm
4	with tools and wires, diameter greater than or equal to 1 mm	grain-shaped foreign bodies, diameter greater than or equal to 1 mm
5	complete protection	dust deposit
6	complete protection	ingress of dust

Protection against water	
IP 2nd digit	
0	no protection
1	vertically falling drops of water
2	obliquely falling drops of water up to 15° towards vertical
3	spray water up to 60° towards vertical
4	splash water from all sides
5	jets of water
6	powerful jets of water
7	partial immersion
8	immersion

Application aspects

How to specify enclosures with regard to the environmental conditions and in respect to the safety requirements for the operating personnel? In the worst case, the environmental conditions inside of a building may consist of the impact of sprinklers and dust generated from industrial processes. To protect the equipment inside of an electronic/electrical cabinet from these conditions, most likely IP 43 would be applicable. The

safety requirements for the protection of the operating personnel would be covered as well since foreign bodies greater 1 mm diameter could not enter the enclosure. For indoor enclosures, IEC 61587-1 suggests IP 54 for worst case conditions. For outdoor enclosures on non-weather protected places, IEC 61969-3 suggests IP 55 for worst case conditions.

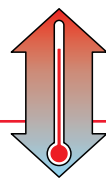

8.00 Thermal management

Thermal management, as described in IEC 62194-1, contains the guide lines for thermal performance evaluation for different enclosure designs. The heat calculation examples as shown are derived from a simplified formula for the general selection of possible heat management solutions.

Figure 27

Example for calculation 1 and 2
Indoor application
Single wall enclosure 2000 x 800 x 600 mm

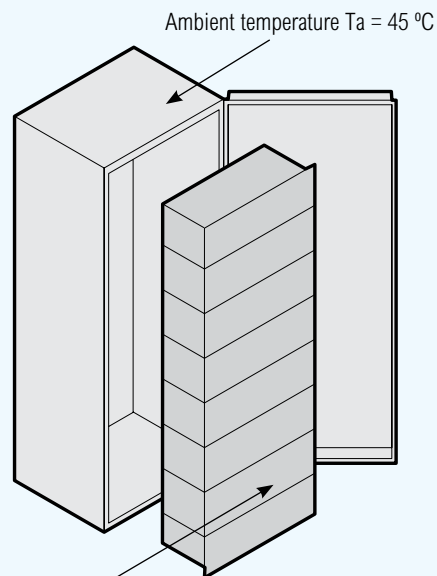

Heat generated inside 1000 W

Max. inside temperature

- 1) 30 °C
- 2) 60 °C

Figure 28

Example for calculation 3
Outdoor application
Double wall enclosure 2000 x 800 x 600 mm

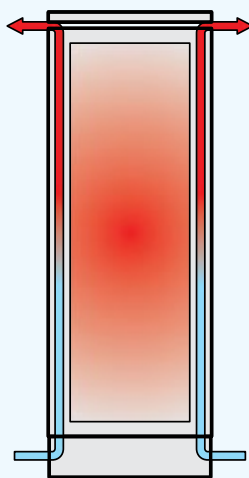

Formula

$$P = k \times A \times \Delta T$$

P = Power (W)

k = Heat transfer coefficient (W/m² x K)

A = Effective enclosure surface

ΔT = Difference of inside to outside temperature (Ti-Ta)

Ti = Cabinet internal temperature

Ta = ambient temperature

8.00

Example 1

Assuming the following parameters in

an enclosure in indoor environment:

Enclosure internal power loss = 1000 W

k = 5 W/m² x K (for 1.5 mm steel)

A = 5 m² (Enclosure effect. surface)

ΔT = assumed Ti 30 °C - Ta 45 °C = -15 °K

P = 5 x 5 m² x (-15 °K) = -375 W

375 W heat transfer from outside to inside.

Result: An air conditioner is required,

total heat to be dissipated:

1000 W + 375 W = 1375 W.

Example 2

Same parameter as before but:

ΔT = assumed Ti 60 °C - Ta 45 °C = 15 °K

P = 5 x 5 m² x (15 °K) = 375 W

375 W heat transfer from inside to outside.

Result: A heat exchanger can be used,

total heat to be dissipated:

1000 W - 375 W = 625 W.

Example 3

Same parameters as for example 1 and 2 but

an enclosure in outdoor environment:

Enclosure internal power loss = 1000 W.

ΔT = Assumed Ti 60 °C - Ta 45 °C = 15 °K

Sun radiation causes an outside to inside

heat transfer of 850 W.

Solution: Ventilated double wall design will eliminate absorbed sun radiated heat.

Result: A heat exchanger is applicable, with a capacity of: 1000 W at 15 °K.

9.00 VME and CPCI **CompactPCI®**

9.00

VME and CPCI are computing architectures developed and specified as open standard platforms. For the mechanical structure on subrack level both systems use common standards: IEC 60297-3-101, -102, -103 IEEE 1101.1, 1101.10 and 1101.11.

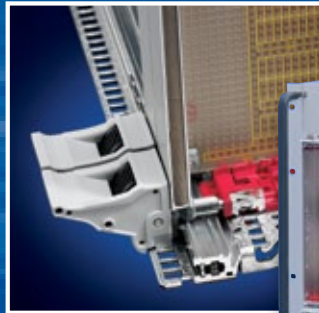

The IEC standards as detailed above contain all details of the mechanical design for VME and CPCI. Compared with IEEE 1101.1 standards it will be found that IEC contents are organized differently.

VME and CPCI both use the Eurocard form factor, that means that the mounting dimensions of the subracks and the pluggable modules are compatible. They differ from each other

mechanically in some details like gasketing, keying, lever handles and connectors.

VME uses IEC 60603-2 type connectors (three rows of 32 contacts), VME 64 X uses IEC 61076-4-113 type connectors (five rows of contacts), together with IEC 61076-4-101 type connectors (2-mm grid with five rows of signals and two GND rows of contacts). Compact PCI uses IEC 61076-4-101 type connectors.

The main features of the mechanical structure are: 3, 6, and 9 U high 19" wide subracks and associated plug-in units. Injector/extractor handles, EMC gaskets for front panels, ESD provision on guide rails, keying and alignment provisions between front panels and subracks and the implementation of RTM's (Rear Transition Modules).

10.00 AdvancedTCA® - PICMG 3.0 **AdvancedTCA™**

10.00

AdvancedTCA® (TCA = Telecom Computing Architecture) is a product specification developed by the PICMG (PICMG = PCI Industrial Computers Manufacturers Group. PCI = Peripheral Component Interconnect).



The dimensions of the mechanical structure for equipment is described in PICMG 3.0. This specification basically defines the dimensions of one slot of a FRU (FRU = Field Replaceable Unit) which is in terms of IEC 60297-3-101, -102, -103 the form factor of a 8 U printed board (H x D = 322.25 x 280 mm). The slot width is 6 x 5.08 mm, or 6 horizontal pitches (HP). The depth of the subrack allows the accommodation of 280 mm deep FRU's and 70 mm deep RTM's (Rear Transition Modules). For the simplicity

of the subrack and the plug-in units mechanics some dimensions have been defined differently from the IEC 60297-3-101, -102, -103 standards series, which creates incompatibility between IEC type and ATCA subracks and plug-in units. The ATCA width of the subrack may come in several different versions for mounting in 19", 23" or ETS cabinets. The ATCA specification also contains functional details like ESD, EMC and Hot-swap in conjunction with a special injector/extractor handle.

Figure 29

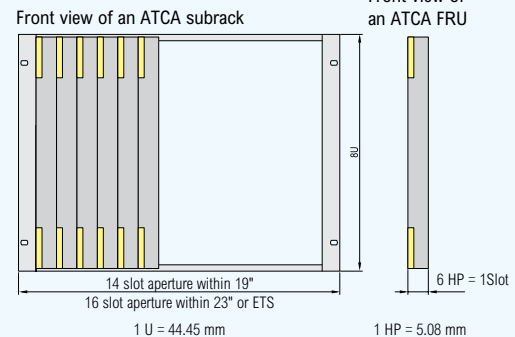
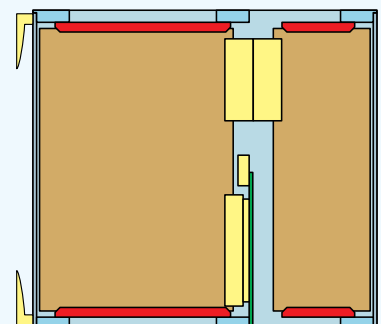

Figure 30

Side view cross section: Interconnect of FRU's and RTM's



About Pentair Technical Products

Pentair Technical Products, a Pentair global business unit, is the leading provider of worldwide product and service solutions for enclosing, protecting and cooling electrical and electronic systems. Its industry-leading brands—Hoffman®, Schroff® and McLean® Cooling Technology—provide a broad variety of standard, modified and engineered solutions to the commercial, communications, energy, general electronics, industrial, infrastructure, medical and security and defense markets.

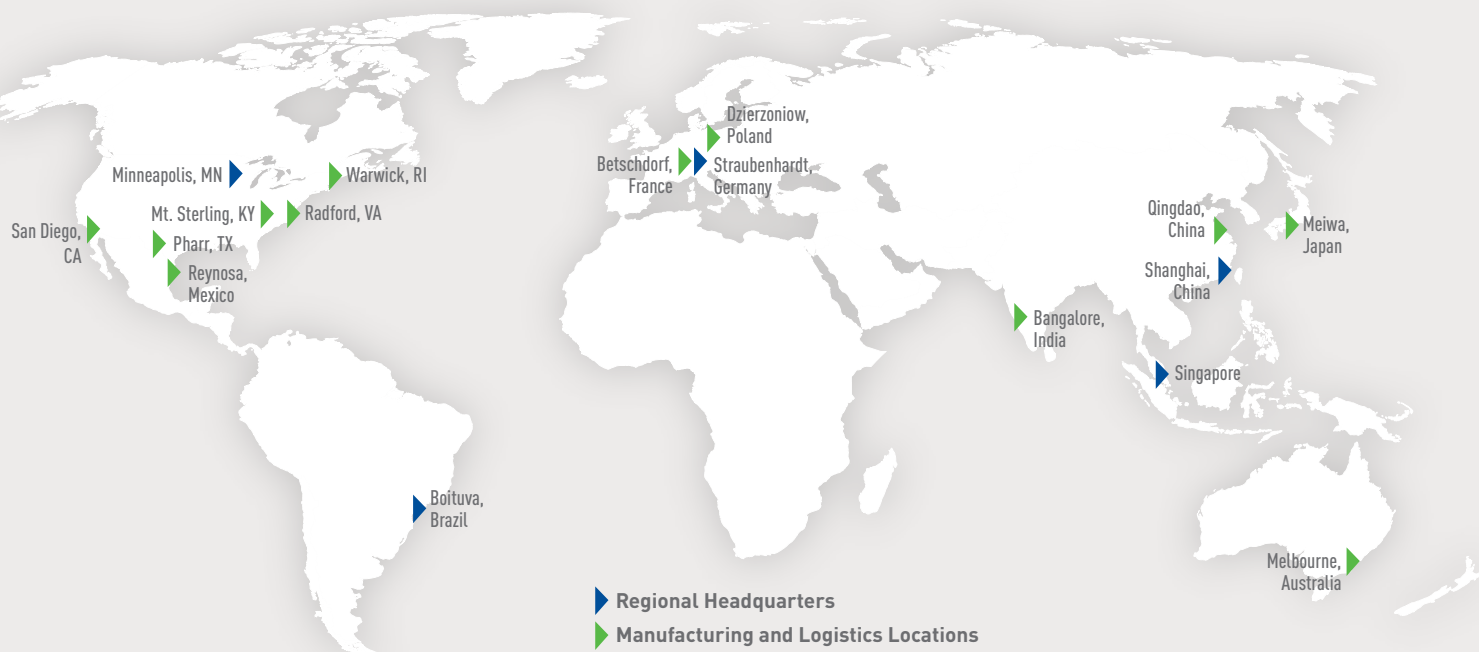

NORTH AMERICA

Pentair Technical Products

2100 Hoffman Way
 Minneapolis, MN 55303-1745
 Tel: +1 (763) 421-2240

170 Commerce Drive
 Warwick, RI 02886
 Tel: +1 (401) 732-3770

7328 Trade Street
 San Diego, CA 92121
 Tel: +1 (858) 740-2400

1120 Rock Road
 Radford, VA 24141
 Tel: +1 (540) 639-4440

Pentair Technical Products

Hoffman Enclosures Inc.
 111 Grangeway Ave., #504
 Scarborough, ON M1H 3E9
 Tel: +1 (416) 289-2770

Pentair Technical Products

Hoffman Enclosures Mexico,
 S. de R.L. de C.V.
 Arquimedes 33 Piso 1
 Colonia Palmas Polanco
 Mexico DF 11560
 Tel: +52 55 5280 1449

SOUTH AMERICA

Pentair Technical Products

Pentair Taunus Electrometalurgica Ltda
 Rua Joao Marcon, 165
 18550.000 – Centro Boituva – SP Brazil
 Tel: +55 15 3363 9100

EUROPE

Pentair Technical Products

Schroff GmbH
 Langenalber Straße 96-100
 75334 Straubenhardt, Germany
 Tel: +49 (0)7082 794-0

Pentair Technical Products

Schroff UK Ltd.
 Unit 4, Grovelands Business Estate
 Boundary Way
 Hemel Hempstead
 Hertfordshire, HP2 7TE
 Tel: +44 (0)1442 240 471

Pentair Technical Products

Schroff SAS
 Z.I. 4, rue du Marais
 Boîte Postale 16
 67660 Betschdorf, France
 Tel: +33 (0)3 88 90 64 90

EUROPE

Pentair Technical Products

Schroff Scandinavia AB
 Flygfältsgatan 11
 P.O. Box 2003
 12821 Skarpnäck, Sweden
 Tel: +46 (0) 8 683 61 00

Pentair Technical Products

Schroff Scandinavia AB
 Peräsimentie 8
 FIN-03100 Nummela
 Finland
 Tel: +358 9 222 68 00

Pentair Technical Products

Schroff S.r.l.
 Via Brughiera 1
 20010 Pregnana Milanese (MI)
 Italy
 Tel: +39 02 932 714-1

Pentair Technical Products

Pentair Poland
 Sp.z.o.o.
 ul. Marynarska 21
 PL-02-674 Warszawa Poland
 Tel: +48 (0) 22 607 06 16

ASIA

Pentair Technical Products

21st Floor of Cloud Nine Plaza
 No. 1118 West Yan'an Road
 Changning District, Shanghai
 P.R. China
 Tel: +86 400 820 1133

Pentair Technical Products India Pvt. Ltd.

Unit 1, Factory 2
 (Sai Lakshmi Industrial Campus)
 Kannamangala, Bidarahalli Hobli
 Whitefield – Hoskote Road
 Bangalore – 560 067
 Tel: +91 80 2845 4640

Pentair Technical Products

Hoffman Schroff Pte Ltd.
 18 Boon Lay Way
 TradeHub 21, #04-110/111
 Singapore 609966
 Tel: +65 6795 2213

Pentair Technical Products

Schroff K.K.
 Nisso No.13 Bldg. 4F
 2-5-1 Shinyokohama
 Kohoku-ku yokohama-shi
 Kanagawa 222-0033 Japan
 Tel: +81 (0)45 476 02 81



2100 HOFFMAN WAY, MINNEAPOLIS, MN 55303 WWW.PENTAIRTECHNICALPRODUCTS.COM

©2012 Pentair Technical Products

Printed in the USA BR0-00101 A