

Panel feed-through terminal block - UW 4-POT-SCM/S - 3056909

Please be informed that the data shown in this PDF Document is generated from our Online Catalog. Please find the complete data in the user's documentation. Our General Terms of Use for Downloads are valid (<http://phoenixcontact.com/download>)



Panel feed-through terminal block, Connection method: Screw connection, Slip-on connection, Load current : 41 A, Cross section: 0.2 mm² - 6 mm², AWG 24 - 10, Width: 8.1 mm, Color: gray

Why buy this product

- Easy grouping with engagement pin versions
- Both terminal halves can be easily assembled by simply snapping them together
- Touch-proof insulating housing in a new design
- Molded type ensures maximum seal and is available with a slip-on or solder connection.
- Universal screw connection with screw locking
- Spacer plates increase clearances and creepage distances
- Automatic compensation of the panel thickness via the snap principle integrated in the insulation housing

Key Commercial Data

Packing unit	50 STK
GTIN	 4 046356 513883

Technical data

General

Number of levels	1
Number of connections	2
Nominal cross section	4 mm ²
Color	gray
Insulating material	PA
Flammability rating according to UL 94	V0
Rated surge voltage	6 kV
Degree of pollution	3
Overvoltage category	III
Insulating material group	I
Ambient temperature (operation)	-40 °C ... 105 °C
Connection in acc. with standard	IEC 60947-7-1
Nominal current I _N	32 A
Maximum load current	41 A (with 6 mm ² conductor cross section)

Panel feed-through terminal block - UW 4-POT-SCM/S - 3056909

Technical data

General

Nominal voltage U_N	800 V (with spacer plate)
Open side panel	No
Number of positions	1

Dimensions

Width	8.1 mm
Plate thickness	1 mm ... 4 mm

Connection data

Connection side	Outside
Connection method	Screw connection
Conductor cross section solid min.	0.2 mm ²
Conductor cross section solid max.	6 mm ²
Conductor cross section flexible min.	0.2 mm ²
Conductor cross section flexible max.	4 mm ²
Conductor cross section AWG min.	24
Conductor cross section AWG max.	10
Conductor cross section flexible, with ferrule without plastic sleeve min.	0.25 mm ²
Conductor cross section flexible, with ferrule without plastic sleeve max.	4 mm ²
Conductor cross section flexible, with ferrule with plastic sleeve min.	0.25 mm ²
Conductor cross section flexible, with ferrule with plastic sleeve max.	4 mm ²
2 conductors with same cross section, solid min.	0.2 mm ²
2 conductors with same cross section, solid max.	1.5 mm ²
2 conductors with same cross section, stranded min.	0.2 mm ²
2 conductors with same cross section, stranded max.	1.5 mm ²
2 conductors with same cross section, stranded, ferrules without plastic sleeve, min.	0.25 mm ²
2 conductors with same cross section, stranded, ferrules without plastic sleeve, max.	1.5 mm ²
2 conductors with same cross section, stranded, TWIN ferrules with plastic sleeve, min.	0.5 mm ²
2 conductors with same cross section, stranded, TWIN ferrules with plastic sleeve, max.	2.5 mm ²
Cross section with insertion bridge, solid max.	4 mm ²
Cross section with insertion bridge, stranded max.	2.5 mm ²
Stripping length	10 mm
Internal cylindrical gage	A4
Screw thread	M3
Tightening torque, min	0.6 Nm
Tightening torque max	0.8 Nm
Connection side	Inside
Connection method	Slip-on connection
Slip-on connection	6.3 x 0.8 mm

Panel feed-through terminal block - UW 4-POT-SCM/S - 3056909

Technical data

Standards and Regulations

Connection in acc. with standard	UL
	IEC 60947-7-1
Flammability rating according to UL 94	V0

Classifications

eCl@ss

eCl@ss 4.0	27141131
eCl@ss 4.1	27141131
eCl@ss 5.0	27141134
eCl@ss 5.1	27141134
eCl@ss 6.0	27141134
eCl@ss 7.0	27141134
eCl@ss 8.0	27141134

ETIM

ETIM 4.0	EC001283
ETIM 5.0	EC001283

UNSPSC

UNSPSC 6.01	30211811
UNSPSC 7.0901	39121410
UNSPSC 11	39121410
UNSPSC 12.01	39121410
UNSPSC 13.2	39121410

Approvals

Approvals

Approvals

UL Recognized / EAC

Ex Approvals

Approvals submitted

Approval details

Panel feed-through terminal block - UW 4-POT-SCM/S - 3056909

Approvals

UL Recognized			
	B	C	D
mm ² /AWG/kcmil	24-10	24-10	24-10
Nominal current I _N	30 A	30 A	5 A
Nominal voltage U _N	300 V	300 V	600 V

EAC

Drawings

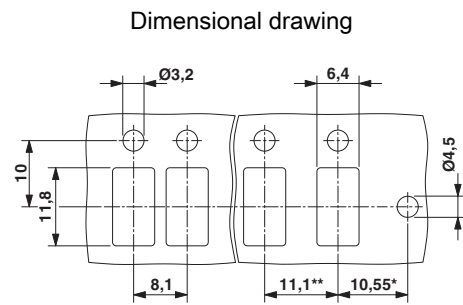
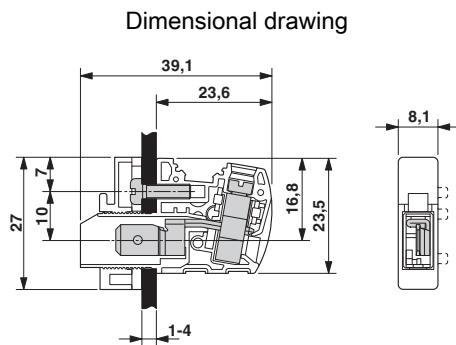

* Only when using the UW...-F flange plate
 ** Dimensions when using the DP-UW... spacer plate

Phoenix Contact 2016 © - all rights reserved
<http://www.phoenixcontact.com>

PHOENIX CONTACT GmbH & Co. KG
 Flachsmarktstr. 8
 32825 Blomberg
 Germany
 Tel. +49 5235 300
 Fax +49 5235 3 41200
<http://www.phoenixcontact.com>