









125-kHz Electromagnetic Inductive RFID System with Multi-Tag Read/Write Functionality

Compact Read/Write Tags Ensure Long Communications Distance and Resist a Temperature of 180°C



### Ordering Information

Product	Shape/Specification		Part number	
ID Tag	20 dia. x 2.7 mm thick	128 bytes with user area of 112 bytes	<b>V700-D13P31</b> (Coin-shaped)	
	23 dia. x 1.2 mm thick	128 bytes with user area of 112 bytes	<b>V700-D13P21</b> (Thin, enclosed-mounting)	
Antenna	250 x 200 x 35 mm	10-cm cable (The connector is not waterproof.)	<b>V700-H01</b> (Standard Antenna)	
	650 x 200 x 35 mm	10-cm cable (The connector is not waterproof.)	<b>V700-H02</b> (Wide-field Antenna)	
Controller	<ul style="list-style-type: none"> <li>• 24 VDC</li> <li>• 1-channel Antenna</li> <li>• 90 x 65 x 75 mm</li> </ul>	RS-232C host interface	<b>V700-CD1D</b>	
Antenna Cable	<ul style="list-style-type: none"> <li>• Material: Vinyl chloride</li> </ul>	2 m	<b>V700-A40</b>	
		3 m	<b>V700-A41</b>	
		5 m	<b>V700-A42</b>	
		10 m	<b>V700-A43</b>	
		20 m	<b>V700-A44</b>	
		30 m	<b>V700-A45</b>	
Programming Console	The following V700-P10 Programming Console Conversion Cable are required.		<b>C200H-PRO27-E</b>	
Programming Console Conversion Cable with keysheet	Cable length: 2 m		<b>V700-P10</b>	

# General Specifications

## ■ ID TAG

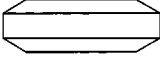
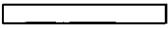
Specification	Coin-shape Tag	Thin, enclosed-mounting Tag
Model number	V700-D13P31	V700-D13P21
Shape		
Weight	Approx. 2 g	Approx. 2 g
Ambient operating temperature	-20°C to 70°C (-4°F to 158°F)	-10°C to 50°C (14°F to 122°F)
Ambient storage temperature	-40°C to 110°C (-40°F to 230°F)	-10°C to 50°C (14°F to 122°F)
Heat resistance	Thermal cycle: 25°C/180°C, 30 min each, 200 times Constant high temperature: 180°C for 200 hours	The above ambient storage temperature range
Degree of protection	IP68 (IEC60529)	IP30 (IEC60529)
Chemical resistance	May be dipped into a variety of chemicals	No
Vibration resistance	Destruction: 10 to 2,000 Hz, 1.5 mm single amplitude or 300 m/s <sup>2</sup> for 15-min sweeping.	Destruction: 10 to 500 Hz, 1.0 mm single amplitude or 150 m/s <sup>2</sup> for 11-min sweeping.
Shock resistance	Destruction: 1,000 m/s <sup>2</sup>	Destruction: 500 m/s <sup>2</sup>
Material	PPS resin	PBT resin
Memory capacity	128 bytes (user area: 112 bytes)	
Memory type	EE-PROM	

## ■ ANTENNA

Item	Specification	
Model number	V700-H01	V700-H02
Oscillation frequency	125 kHz	
Ambient operating temperature	-20°C to 55°C (-4°F to 131°F)	
Ambient operating humidity	25% to 85% (with no condensation)	
Ambient storage temperature	-35°C to 65°C (-31°F to 149°F)	
Shape	Standard Antenna: 250 x 200 x 35 (mm)	Wide-field Antenna: 650 x 200 x 35 (mm)
Degree of protection	IP40 (IEC605209)	
Material	PC/ASA resin	
Cable length	10 cm (may be extended up to 50 m with an extension cable)	
Weight	Approx. 800 g	Approx. 1,800 g

## ■ CONTROLLER

Item	Specification
Part number	V700-CD1D
Supply voltage	24 VDC $+10\%/_{-15\%}$
Ambient operating temperature	-10°C to 55°C (14°F to 131°F)
Ambient operating humidity	25% to 85% (with no condensation)
Shape	90 x 65 x 75 (mm)
Degree of protection	Enclosed-mounting
Material	ABS resin
Number of connectable Antennas	1 channel
Host interface	Conforms to RS-232C
Function	Communications test, measurement of noise environment, error logging, monitoring of communications condition, and antenna mutual interference prevention
Standards/Approvals	See Appendix B
Weight	Approx. 290 g

Note: By connecting the Programming Console to the Controller, the communications condition monitoring, set value display, communications, communications test, noise environmental measurement, and error logging functions are available.

## System Configuration

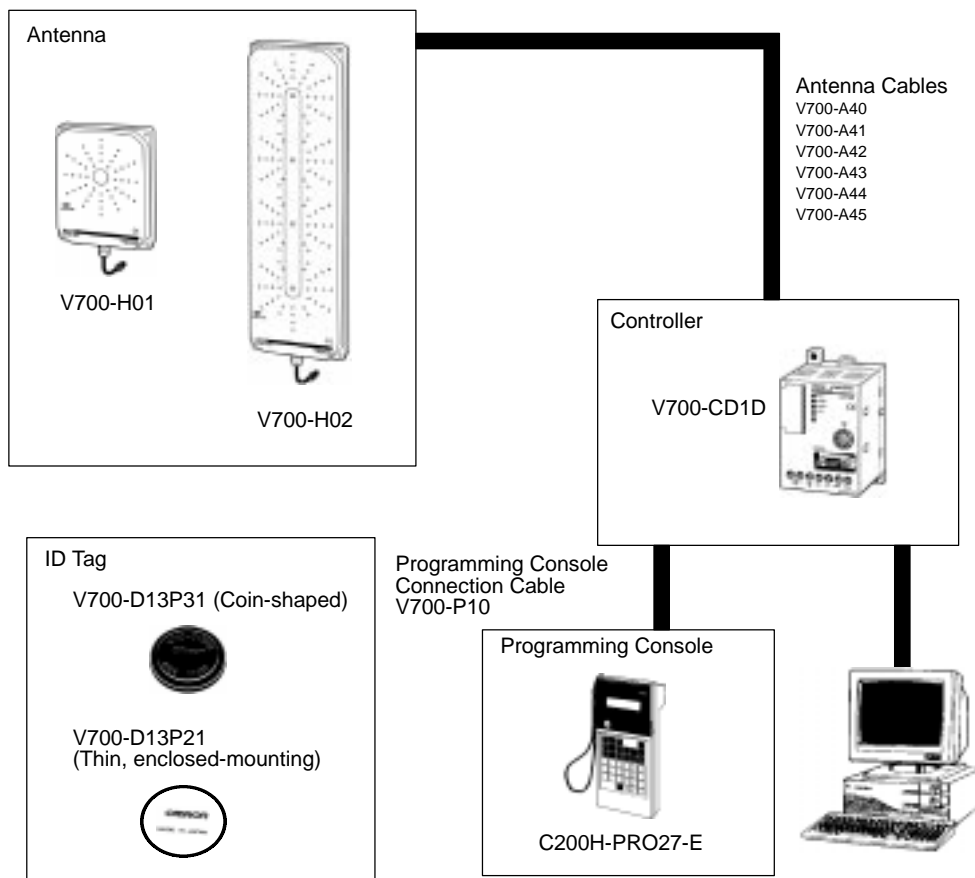

Note: Use the mutual interference preventive function if more than one Antenna is set up. Refer to the Operation Manual for the mutual interference preventive function in detail.

# Communications Specifications

## ■ COMMUNICATIONS DISTANCE (MAX. ACTUAL VALUE/REFERENCE VALUE)

Specification	Read distance	Write distance
Coin-shaped/Thin Tag	0 to 250 mm	0 to 250 mm

## ■ COMMUNICATIONS TIME (REFERENCE VALUE)

Part number	Number of bytes	Read time			Write time	
		Asynchronous	Read-only synchronization	R/W synchronization	Asynchronous	R/W synchronization
Coin-shaped Tag (V700-D13P31)	8	105	151	170	164	223
	16	151	198	223	217	276
Thin Tag (V700-D13P21)	32	245	291	328	322	381
	64	431	478	540	533	592
	112	700	758	856	850	909

## ■ SYNCHRONIZATION METHODS

If more than one Antenna exists within 15 m, all the Antennas must be synchronized to prevent mutual interference. There are two ways to synchronize them.

### Read-only Synchronization

Used when only read commands are transmitted through all the Antennas. Access time can be reduced with this synchronization method.

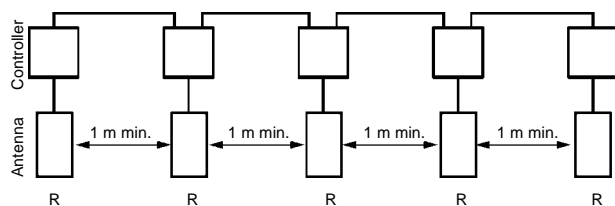

### Read/Write Synchronization

Normally used. Both the read and write commands can be used by synchronizing more than one Antenna

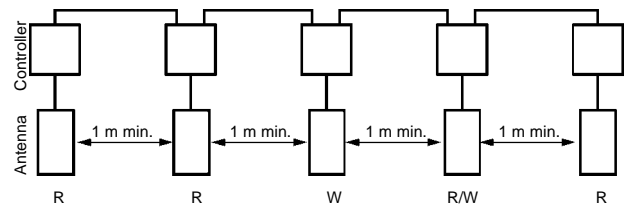

### Communications Function

Item	Coin-shaped Tag (V700-D13P31)	Thin Tag (V700-D13P21)
1-to-1 Read/Write	Yes	
FIFO (first-in first-out) (read/write)	Yes	
1-to-N communications time (reference value) for 8-byte data reading	5-piece reading: Approximately 0.6 s 10-piece reading: Approximately 1.3 s	
Communications error check function	CRC check	

### Security Function

Access limit function
Write-protect function per page

Note: Refer to your OMRON representatives for details.

# Communications Function Description

**FIFO**  
(First-in First-out)  
Read/Write

Communications with ID Tags occur in sequence when the ID Tags are in the communications area.

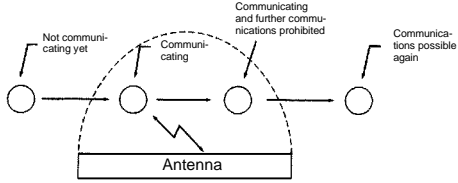

**Multiple, Simultaneous Access Function**  
(1-to-N read/write)

Communications with all ID Tags in the communications area occur on receipt of the command.

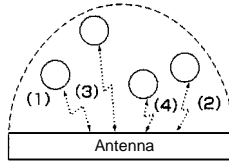

## Antenna Beam Pattern

Mode: WRITE (16 bytes)

### ■ V700-H01

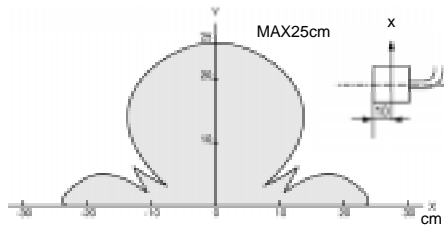

### ■ V700-H02

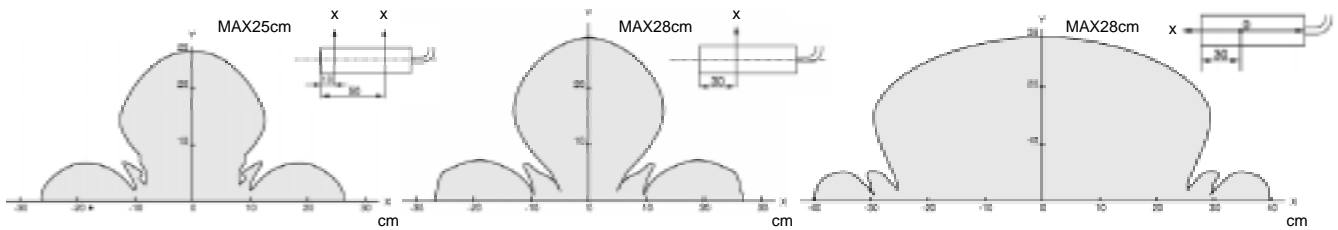

## Influence of Background Metal Antenna

### ■ V700-H01

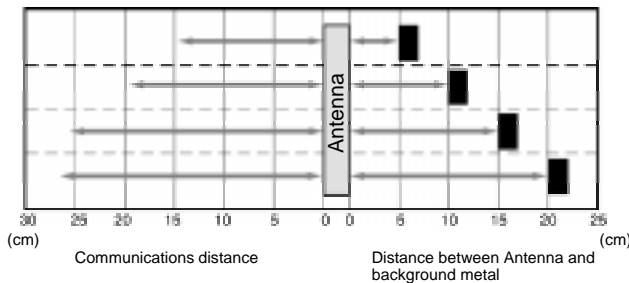

### ■ V700-H02

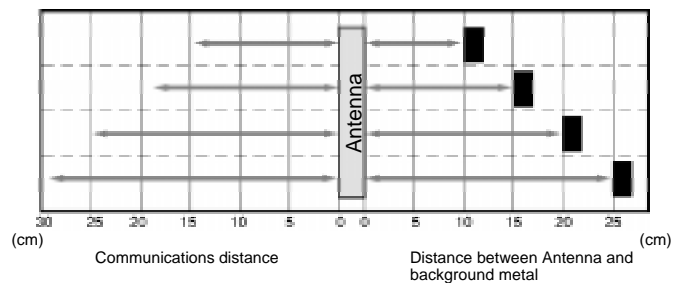

# Dimensions

Unit: mm (inch)

## ■ ID TAG

V700-D13P31 Coin-shaped Tag

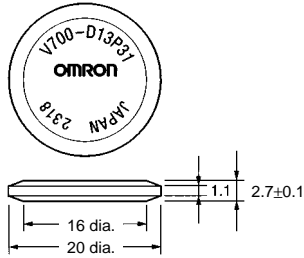

V700-D13P21 Thin, Enclosed-mounting Tag

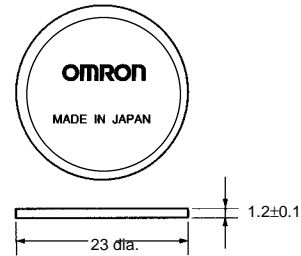

## ■ ANTENNA

V700-H01 Standard Antenna

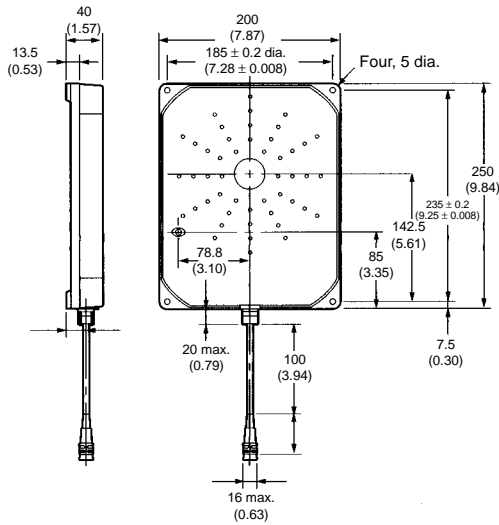

V700-H02 Wide-field Antenna

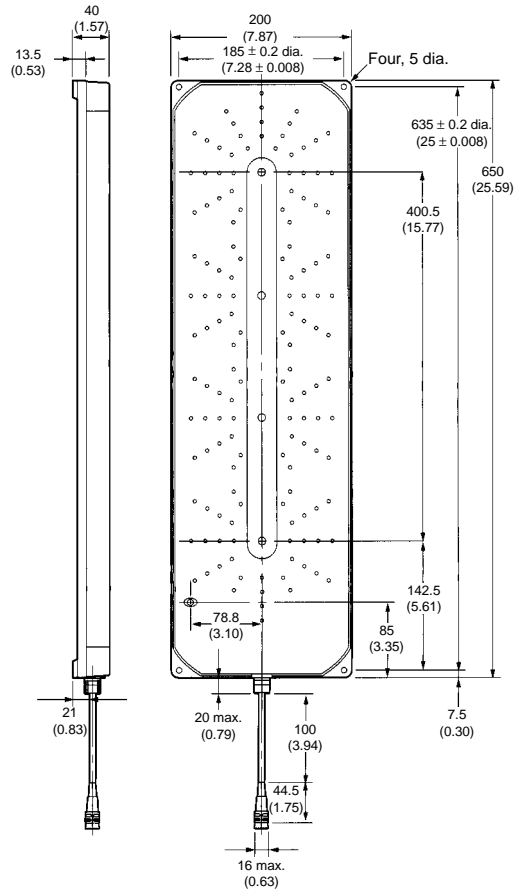

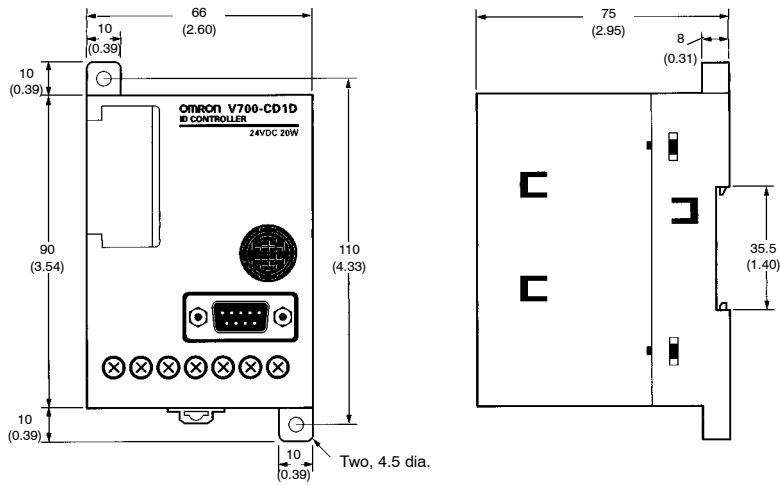

■ CONTROLLER

V700-CD1D One-channel General-purpose Controller



■ ADDITIONAL PRODUCTS

<p>Compact Reader/Writer 40 (W) x 53 (H) x 23 (D) mm</p>	<p>V700-HMD11</p> 	<p>A compact model with a reader/writer antenna and controller functions is ideal as a built-in device for equipment. Output data can be directly connected to the host via RS-232C.</p>
<p>PCB-mounting Reader/Writer Module Large: 80 (W) x 80 (H) x 5 (D) mm Small: 40 (W) x 44 (H) x 12 (D) mm</p>	<p>V700-HMC73</p>  <p>V700-HMC71</p>	<p>A read/write antenna and controller functions are built into a compact module, which facilitates mounting to other equipment. Output level is 5 V with C-MOS.</p>

Note: This data sheet mainly provides information required for model selection and information on operational precautions is not provided. Before using any product, be sure to familiarize yourself with the Operation Manuals.

**NOTE: DIMENSIONS SHOWN ARE IN MILLIMETERS. To convert millimeters to inches divide by 25.4.**

**OMRON**<sup>®</sup>  
**OMRON ELECTRONICS, INC.**  
 One East Commerce Drive  
 Schaumburg, IL 60173  
**1-800-55-OMRON**

**OMRON CANADA, INC.**  
 885 Milner Avenue  
 Scarborough, Ontario M1B 5V8  
**416-286-6465**