

D8 - SERIES

SPECIFICATIONS AND ORDERING INFORMATION

58.74 mm DIAMETER 2.25 AMPS @ 28 VDC

The D8 Series switches are heavy duty, 18 position, 20° index, and glass epoxy insulation. Double eyelet construction is standard to assist in supporting larger wiring harness applications. Positive indexing is provided by a dual-ball, hill and valley index assembly.



SPECIFICATIONS

ELECTRICAL

Current and Voltage Rating: Make and break resistive load
2.25 amps @ 28 VDC; 1.0 amp @ 115 VAC.
Current Carrying Capacity: 9 amps.
Dielectric Strength: 1,000 VAC between current carrying parts and ground.
Contact Resistance: Average initial 5 milliohms.
Insulation Resistance: In excess of 750,000 megohms.

Hardware: Mounting nut and lockwasher are shipped assembled.

MECHANICAL

Materials and Finishes: All parts utilize non-corrosive materials as standard.
Clips and Rotors: Brass with silver plate as standard.
Insulation: Glass epoxy.
Index: Dual-ball, hill and valley.
Index Life: 25,000 cycles minimum.
Index Torque: Switches have lowest practical torque consistent with crisp detenting and smooth, reliable operation.
Index Angles: Positive 20° standard.
Index Stops: Adjustable standard, fixed or continuous.
Stop Strength: 2.82 Nm minimum.

STANDARD PART NUMBER

GLASS EPOXY INSULATION SWITCHES - 20° INDEXING
ADJUSTABLE STOPS SET @ 2 POS. - SOLDER LUG TERMINALS

POLES	ACTIVE POSITIONS	POLES/ SECTION	NO. OF SECTIONS	SHORTING	NON-SHORTING	FIG. *
01	02-17	1	1	D8G0117S	D8G0117N	DT
02	02-17	1	2	D8G0217S	D8G0217N	DT
03	02-17	1	3	D8G0317S	D8G0317N	DT
04	02-17	1	4	D8G0417S	D8G0417N	DT
05	02-17	1	5	D8G0517S	D8G0517N	DT
06	02-17	1	6	D8G0617S	D8G0617N	DT
07	02-17	1	7	D8G0717S	D8G0717N	DT
08	02-17	1	8	D8G0817S	D8G0817N	DT

* FIGURES ARE SHOWN ON PAGE 57.

DIMENSIONS

STANDARD CONSTRUCTION
D8G - GLASS EPOXY
CONSTRUCTION

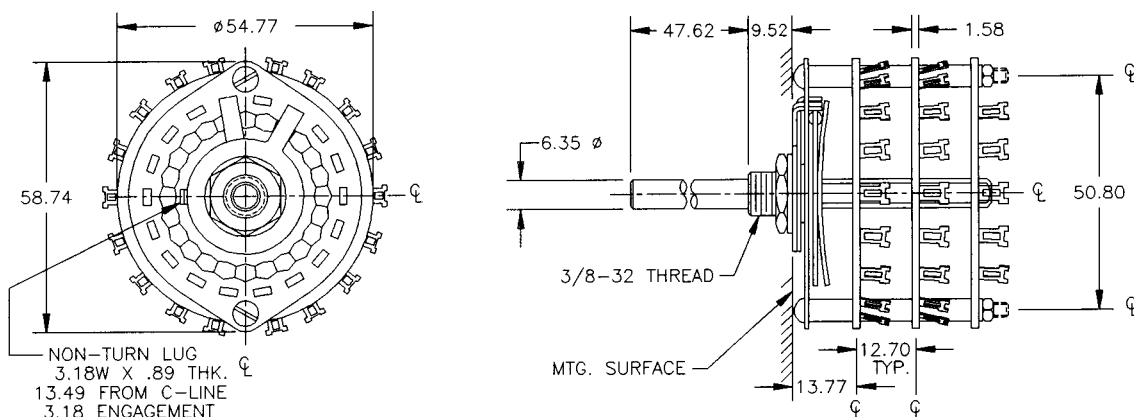

How to Order Additional Options:

2 DIGIT SERIES	INSULATION TYPE	TOTAL POLES	ACTIVE POSITIONS	CONTACT TYPE	STOP TYPE	SHAFT/BUSHING	SHAFT FLAT
D8	G - GLASS	01 - MIN.	18 - MAX @ 20°	N - NON SHORTING S - SHORTING	A - ADJ. F - FIXED C - CONT.	SEE CHART "A"	SEE CHART "B"

CUSTOMERS SPECIFIED ORDER NUMBER FOR STANDARD OPTIONS

D	8	G	<input type="text"/>	<input type="text"/>	<input type="text"/>	<input checked="" type="checkbox"/>
		(SPECIFY)	(SPECIFY)	(SPECIFY)		

ADDITIONAL OPTIONS

<input type="text"/>	<input type="text"/>	<input type="text"/>
(SPECIFY)	(SPECIFY)	(SPECIFY)

SHAFT, BUSHING, AND FLAT OPTIONS

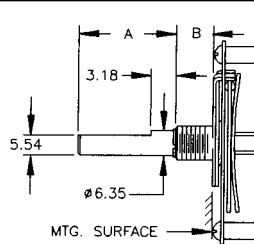

P/N OPT.	SHAFT LGTH. "A"	BUSH. LGTH. "B"
01	9.53	6.35
02	9.53	9.53
03	12.7	6.35
04	12.7	9.53
05	14.29	6.35
06	14.29	9.53
07	19.05	6.35
08	19.05	9.53
09	25.4	6.35
10	25.4	9.53
11	38.1	6.35
12	38.1	9.53
13	47.63	6.35
14	47.63	9.53

P/N OPT.	FLAT ANGLE
B	ROUND
U	10°
W	170°
Y	190°
Z	350°

SHAFT AS VIEWED WITH NON-TURN LUG AT 9 O'CLOCK AND SHAFT IN EXTREME CCW POSITION AND STRUT BOLTS ORIENTED VERTICALLY.

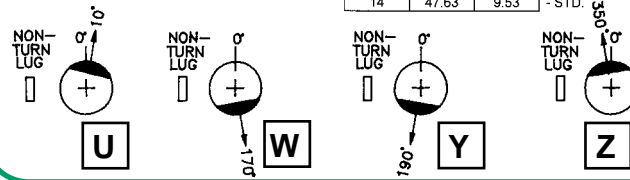

D
M
E
T
R
I
C

CUSTOM SWITCHES ARE AVAILABLE. CONTACT THE FACTORY WITH YOUR COMPLETE SPECIFICATIONS.