

Working With Optically-Isolated Relays

Learn how these solid-state relays can improve the performance of data acquisition systems and industrial machines

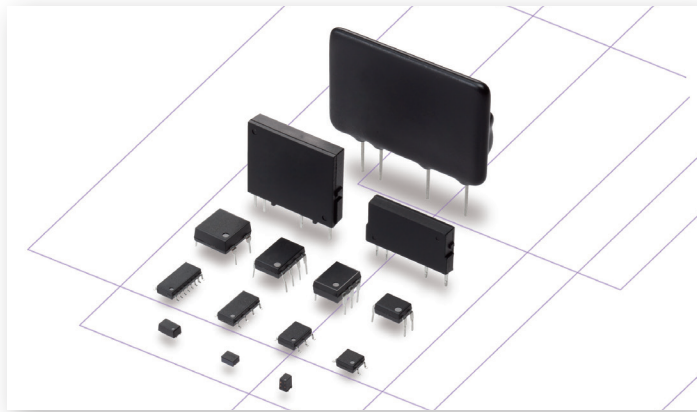

Product lineup of PhotoMOS devices

Not too long ago, all relays performed their switching duties through electromechanical means. Today, however, engineers can also opt for solid-state relays that use semiconductors to switch their output circuits. The choice between traditional electromechanical relays and the solid-state varieties often comes down to reliability and performance.

With no moving parts, solid-state relays avoid all the obvious mechanical failure modes associated with traditional relays. They also tend to offer desirable electrical characteristics and design advantages including:

- Low power consumption.
- Low leakage current.
- Stable on-resistance over lifetime.
- High reliability with extremely long life.
- Small size.
- Fast switching speeds.
- High vibration and shock resistance.
- No contact bounce or switching noise.

Keep in mind that solid-state devices are not created equal when

it comes to these performance advantages. Optically-isolated solid state relays, in particular, can outshine other solid-state devices that use electrical or magnetic operating principles. In this paper, you will learn more about the operating principles of optically-isolated relays, how to apply them in different applications and how to maximize their already-long lifecycles.

PhotoMOS relay

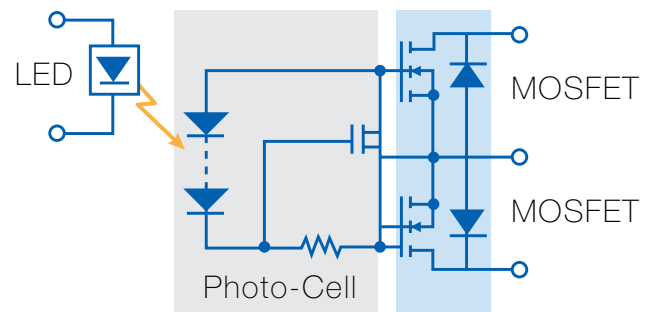

PRINCIPLES OF OPERATION

Optically-isolated relays are characterized by the use of a light emitting diode (LED) on their input side, MOSFETs on the output side and an array of photo sensors in between.

In operation, current flows through the LED, which then emits light. The photo sensor array detects the emitted light, triggering a voltage drop that drives the MOSFETs. The MOSFETs finally switch the load circuit.

The design and packaging of the optical and electronic components are crucial aspects of the relay's performance. The LED and photo array, for example, are molded in a translucent resin that allows light to pass through while providing a dielectric barrier between the input and output.

The most basic method to drive an optically-isolated relay is to apply a switchable voltage directly to the input pin of the

PhotoMOS through a resistor to limit the current through the LED. Choosing the correct RF value for the resistor will ensure that the LED reaches full intensity while preventing it from being overdriven by the input voltage (see Design Tip, “Calculating Input Resistance (RF) Correctly”).

TEST AND MEASUREMENT USES

Most optically-isolated relays today will ultimately become part of sophisticated test and measurement systems. To keep pace with advances in the electronics industry, these systems increasingly require solid-state relays that combine low capacitance, low on-resistance, physical isolation and high linearity.

All these characteristics play an important role as data acquisition devices become faster and more precise:

Low capacitance improves switching times and isolation characteristics for high frequency load signals.

Low on-resistance reduces power dissipation when switching high currents and increases switching speeds to improve the precision of measurement. When considering on-resistance values, pay close attention to the temperature range the relay must withstand. Rising temperatures decrease the mobility of electrons, driving up the on-resistance. Starting with a relay that has low on-resistance will minimize the effects of temperature drift.

Physical isolation. Sometimes referred to as galvanic separation, physical isolation between the relay’s input and output or between different output channels enhances precision by minimizing noise. Optically-isolated relays offer a true physical separation of the input and output, and the best of these products exhibit isolation voltages as high as 5,000 volts AC.

High linearity ensures accurate measurements.

With a variety of signals at work in a typical test system, it’s particularly important to find relays that offer the right combination of electrical characteristics. For example, many systems have both DC and AC switching needs and will require relays that combine low-on-resistance and low capacitance: The low on-resistance minimizes signal loss when switching DC signals, while low capacitance improves isolation when switching AC signals.

INDUSTRIAL APPLICATIONS TOO

Not all optically-isolated relays end up in test and measurement applications. Increasingly,

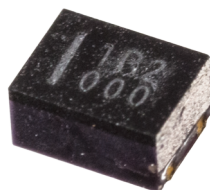

these relays also switch and protect small motors, power supplies and control devices with load currents up to 10 amps.

These industrial uses represent the next wave of applications for optically-isolated relay technology, which has been widely accepted as a way to switch high-precision data acquisition and measurement systems.

Like test and measurement systems, industrial equipment can benefit from high switching speeds, low on-resistance, low capacitance and small package size. Yet motors, power supplies and controls can reap additional benefits by moving from traditional electromechanical relays to optically-isolated relays:

Low Power Consumption. A typical optically-isolated relay requires 10 to 20 times less power than an equivalent electromechanical relay. For example, a 5 mA PhotoMOS can often do the same job as an electromechanical relay that requires anywhere from 50 to 100 mA, depending on the electromagnetic force needed to close the coil. A few milliamps here or there may not sound like a big deal, but in a plant with many small devices the savings add up quickly.

Protection. Thanks to a built-in protective circuit in our latching-type models, PhotoMOS can safeguard motors, power supplies and other industrial devices from possible disturbances on the output side. These disturbances—such as voltage peaks or overcurrent conditions—can arise due to short circuits or improper use. The protective circuit is located on the output side of the component and recognizes high currents. This arrangement protects both the DMOSFET on the output side and the load circuit against overcurrent conditions. As soon as a dangerous load current arises, the load circuit switches off completely. It can be switched on again only after the input signal has been reset.

Elevated Temperature Tolerance. The PhotoMOS protective circuit can play a particularly important role when the relay must perform at elevated operating temperatures. Because the voltage drop across the shunt increases as rising temperatures drive up resistance in the component, the protective circuit responds to lower and lower current levels as temperatures rise. In essence, it exhibits a negative temperature coefficient, which allows it to offset the increased power dissipation associated with elevated temperatures.

Reliability. Solid-state relays such as PhotoMOS shine when it comes to reliability. Without the moving parts of an electromechanical relay, solid-state relays typically have an excellent mean time to failure (MTTF). In general, solid-

state relays tolerate shock and vibration loads that threaten electromechanical relays. Solid-state relays also eliminate the buzzing that can affect electromechanical relays driven by PWM and other methods intended to conserve input power.

Low operating cost. Solid-state relays may have a higher price tag than electromechanical relays. The total cost over the relay's life-cycle, however, tips the scales back in favor of solid-state technology. Most of the operating cost advantages come from reductions in power consumption and a longer life-cycle for fewer relay replacements. Factor in the cost benefit of

motor protection and the value proposition becomes even more compelling. Keep in mind, too, that the savings can be greater in applications that require the relay to remain in its closed state for long periods of time. Solid-state relays can be operated closed without the elevated temperatures and extra current draw of their electromechanical counterparts.

Saves space, speeds development. Integrating the protective mechanism in the relay, rather than relying on a separate component, saves space. And it speeds development time because there's one less component to work into your design.

DESIGN TIP

Account For LED Power Losses To Maximize Relay Life

Optically-isolated relays inherently have a long lifespan, thanks to their lack of moving parts and the robustness of their solid-state electronics. You can, however, make them last even longer by accounting for LED power losses.

Keep in mind that LED power does not remain constant over time. Instead, all LEDs experience a power loss in proportion to the time that current is applied to them. With optically-isolated relays, including PhotoMOS, this loss of LED power affects the device's operating characteristics and lifecycle.

Rising Currents. As LED power falls, the relay's operating currents will rise accordingly. On a typical PhotoMOS relay, for example, LED power might drop by roughly 3% after a 5 mA input current has been applied for 100,000 hours. As a result, the relay's operating (IFon) and turn off (IFoff) currents would rise from their initial value by 3%.

This change in the electrical characteristics of the PhotoMOS has lifecycle implications. As LED sensitivity degrades with continued usage, more current is needed to generate the same amount of light. This light is used to charge the gates of internal MOSFETs and ultimately turn the relay on.

Slower Turn-On Time. The turn-on time of optically-isolated relays slows as LED power falls. Going back to our example of a 3% degradation of LED power after 100,000 hours at 5 mA, the turn-on time would likewise slow down by 3%. Put differently, a PhotoMOS with a turn-on time of 0.03 mS out of the box will have a turn-on time of 0.0309 mS after 100,000 hours of use at 5 mA.

This slowdown occurs because light intensity diminishes, which reduces the voltage and current output of the photo

diode array in the IC. So it takes longer to bias the MOSFET gates.

Elevated Temperature Effects. At elevated ambient temperatures, more LED current is needed to generate the same amount of lamination. This lamination will then be converted to produce the necessary electrical voltage and current to charge the gates of MOSFETs and maintain ON state.

Careful design is required to set up the series limiting resistance of the input LED to ensure proper operation of the relay across the operating range of the relay.

In many applications, the electrical change related to optically-isolated relays may not make a practical difference. Adding 3% to an already fast on-time, for instance, won't matter in every application.

Yet even incremental changes in performance or lifecycle can be significant in cutting edge applications. Examples include high-speed test and measurement systems,

In these cases, the datasheet alone won't tell you whether you have picked the right relay for the job. You will have to evaluate the relay based on the electrical characteristics that will emerge after an extended period of operation that corresponds to your application.

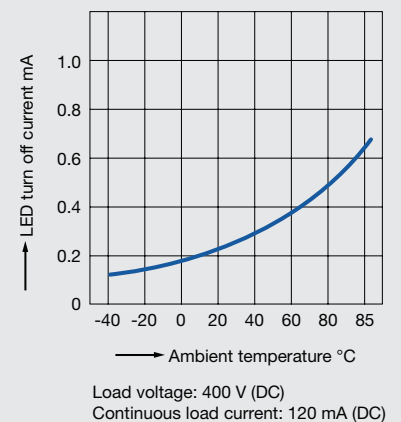

DESIGN TIP

Calculating Input Resistance (RF) Correctly

When calculating the correct R_F value for the resistors used with optically-isolated relays, make sure you take the forward voltage (V_F) into account.

Since the LED operating current increases as the temperature rises, we must use the typical recommended I_F value of 5 mA at the maximum operating temperature of 85°C to ensure safe operation. The LED forward voltage (V_F) depends on the forward current (I_F) and the temperature.

Let's for example calculate the R_F value for a popular Panasonic optically-isolated relay, the AQV210 PhotoMOS. Figure 1 shows the LED forward voltage versus ambient temperature graph for the AQV210 PhotoMOS. The LED V_F with I_F of 5 mA at 85°C is 1.03 V.

The maximum R_F value can be calculated as follows:

$$R_F = \frac{V_{CC} - V_F}{I_{Fon}} = \frac{5V - 1.03V}{5mA} = 794\Omega$$

Assuming a 5% tolerance and a temperature coefficient of 250 ppm (parts per million) per °C, the appropriate R_F value will be the next lower value from the standard resistors: $R_F=680$

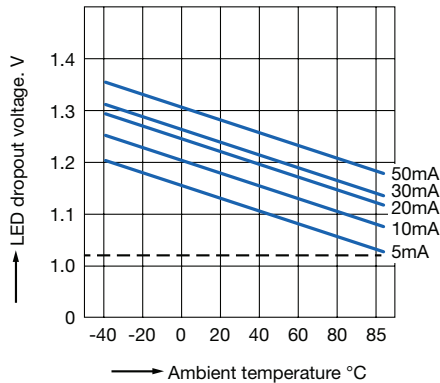

Figure 1:
LED forward voltage vs. ambient temperature

Ω . This margin will ensure safe operation over the entire temperature range. If the supply voltage (V_{CC}) contains a ripple, the lowest possible V_{CC} value should be used for the calculations.

Although power consumption and drive current for optically-isolated relays are significantly lower than electromechanical relays, some logic circuits can not drive the PhotoMOS directly and require some additional components. Using a transistor as a control mechanism to switch an external power supply is one method that is typically used by circuit designers.

In this scenario, the transistor is controlled by the output of the logic circuit. When the transistor is turned on, it will create a path to ground for the power supply V_{CC} thus turning on the LED. When calculating the R_F in this circuit, we must account for the voltage drop, typically 0.4 to 0.7 V, between the collector and the emitter of the transistor.

Using the same example of the AQV210 PhotoMOS, R_F can be calculated as follows: Assuming a 5% tolerance and a temperature coefficient of 250 ppm per °C, R_F of 680 Ω can no longer guarantee safe operation over the entire temperature range. In this case, use the next lower standard resistor to ensure that R_F is lower than the maximum allowed value of 714 Ω : $R_F=560 \Omega$.

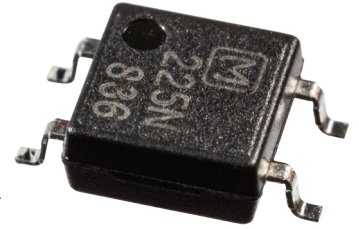

DESIGN TIP

Calculating Mean Time To Failure

Mean Time To Failure (MTTF) equals 1/the failure rate λ .

λ is expressed in terms of failures per unit of time (FIT), where 1 FIT=1 failure per billion device hours.

The failure rate of Panasonic's PhotoMOS optically-isolated relays is 20 FIT which means that MTTF is $1/(20 \times 10^{-9})$ based on the THB test per MIL HDBK-217F.

Based on the MTTF, expected time to first failure exceeds 50 million hours of operation.



Many Types of PhotoMOS Relays

More than 300 different types of PhotoMOS optically-isolated relays are available to meet a wide variety of electrical and package size requirements. The PhotoMOS products most suited to motor protection and other industrial uses include:

[AQZ207 SIL package with 1 A load current.](#)

[AQY277A DIP4 SMD with 0.65 A load current.](#)

[AQV252G with 2.5 A load current.](#)

For test and measurement applications, consider our **Low CxR PhotoMOS** Model AQY221N2M. It offers:

- **Low capacitance of 1.1 pF.** A laterally diffused metal-oxide-semiconductor (MOSFET LDMOS) lowers the relay's capacitance.
- **Low on-resistance of 9.5 ohm.** A vertical-type double-diffused metal-oxide-semiconductor (DMOS) limits the relay's on-resistance.
- **Fast Switching and Physical Isolation.** Thanks to the low capacitance and on-resistance values, this relay supports switching times as fast as 20 μ s and provides the isolation required to switch high-frequency load signals.

- **Linearity.** Optical MOSFET-based relays like PhotoMOS have highly linear input and output characteristics that outshine those of alternatives such as Triacs or OptoCouplers. PhotoMOS relays can also control small analog signals without distortion, unlike Triacs and Bipolar transistors whose offset voltages distort and clip signals.
- **Minimal Signal Propagation Delay.** Measurement applications benefit from a reduced length of internal bonding and flat lead terminals, which results in reduced signal propagation delay.

Besides using **Low CxR PhotoMOS** relays for switching signals and I/O lines to devices being tested, these relays may also be employed in data acquisition circuits. For instance, they can be used to select the gain of operational amplifiers. With the help of an optically-isolated relay, the device's digital control unit and the analog signal system can be physically isolated, enhancing the precision of the device by minimizing noise.

Part Number Builder

Prefix # Term Output Type V-load Function Isolation PKG. T/R-Tube

AQ **A** **B** **C** **D** **E** **F** **G** **H**

A	Y: 4 pin V: 6 pin W: 8 pin S: 16 pin Z: SIL 4		E	nil: Std D: V Drive E: Std G: High Current L: Current Limit N: Low Cout K: ShortCkt Prtctn	KL: SC Self Reset M: Soft On/Off P: DAA Config R: Low Ron T: Optocoupler T2: 2-Optocoupler V: Varistor Prtctn
B	1: 1FA (DC) 2: 1FA (AC/DC) 4: 1FB (AC/DC) 6: 1FA/B (AC/DC)		F	nil: 1,500 V H: 5,000 V	
C	0: HF (Low Ron) 1: GU (General Use) 2: RF (Low Ron Low Co) 3: HS (High Sensitivity) 5: HE (Low Ron) 8: GU (General Use)		G	nil: DIP (Through Hole) A: DIP (Surface Mount) M: SON S: SOP T: VSSOP V: SSOP	
D	0: 350V 1: 30-40V 2: 60-80V 3: 250V 4: 400V	5: 100-150V 6: 600V 7: 200V 8: 1,500V 9: 1,000V	H	nil: Plastic Tube W: T/R 3.5k X: T/R 1k Y: T/R 3.5k Z: T/R 1k	