

PANDUIT PART NUMBER	STUD SIZE	DIMENSIONS in.				
		A ±.03	W ±.01	C ±.02	M ±.03	H ±.01
PV14-4RB-3K	#4	.76 (19.30)	.25 (6.35)	.22 (5.59)	.63 (16.00)	.12 (3.05)
PV14-6RNB-3K	#6	.76 (19.30)	.25 (6.35)	.22 (5.59)	.63 (16.00)	.15 (3.81)
PV14-6RB-3K	#6	.86 (21.84)	.31 (7.87)	.25 (6.35)	.70 (17.78)	.15 (3.81)
PV14-8RB-3K	#8	.86 (21.84)	.31 (7.87)	.25 (6.35)	.70 (17.78)	.17 (4.32)
PV14-10RB-3K	#10	.86 (21.84)	.31 (7.87)	.25 (6.35)	.70 (17.78)	.20 (5.08)
PV14-14RB-3K	1/4"	1.05 (26.67)	.45 (11.43)	.38 (9.65)	.83 (21.08)	.27 (6.86)
PV14-56RB-2K	5/16"	1.06 (26.9)	.46 (11.68)	.38 (9.65)	.83 (21.1)	.33 (8.41)
PV14-38RB-2K	3/8"	1.15 (29.2)	.53 (13.46)	.43 (10.92)	.88 (22.4)	.39 (9.9)

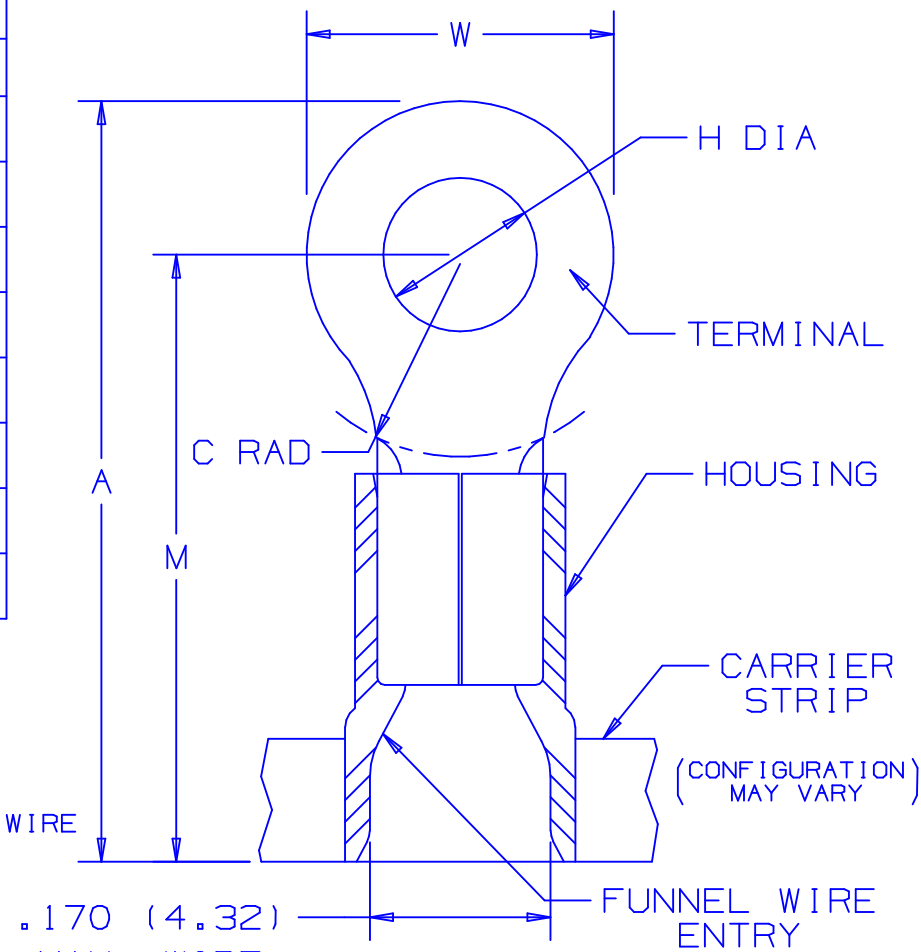

- NOTES :
- UL LISTED AND CSA CERTIFIED FOR :
 - A. 600 V MAX. VOLTAGE RATING
 - B. 221°F (105°C) MAX. TEMP. RATING
 - C. #16-14 AWG (1.5-2.5 mm²) SOLID OR STRANDED, COPPER WIRE
 - PACKAGE QTY. : -3K = 3000 PCS.
-2K = 2000 PCS.
CONTINUOUS MOLDED CARRIER STRIP
 - MATERIAL :
 - A. STAMPING - .03" THK COPPER, TIN PLATED
 - B. HOUSING - BLUE VINYL
 - DIMENSIONS IN BRACKETS ARE IN MILLIMETERS
 - INSTALLATION TOOLS :
 - A. PRESSES - CP-851, CP-860, CP-861, CP-862
 - B. APPLICATOR - CA-800, CA9
 - C. DIE INSERTS - CD-800-2, CD9-2A,2B
 - WIRE STRIP LENGTH: 1/4 ⁺⁰/_{-1/32} (6.4 ⁺⁰/_{-.8})

.170 (4.32)
MAX. WIRE
INSUL. DIA

LISTED
587H
E52164

CERTIFIED
LR31212

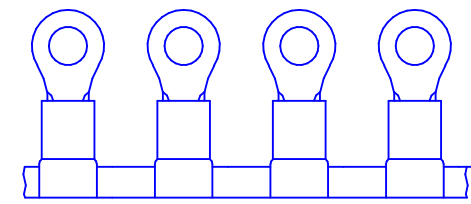

A41068_06

06	1/05	KLFU		ADDED CP-862, CA9 & CD9-2A,2B TO NOTE 5			
05	3/01	SABS	SKB	PV14-56RB-2K WAS PV14-56R, PV14-38RB-2K WAS PV14-38R. ADDED 2K=2000 PCS. TO NOTE 2, AND MODIFIED DIMENSIONS A, M, AND H FOR PV14-56RB AND PV14-38RB	09092	JAC	TRO
---	---	---	---		---	---	---
04	2/97	JAMB	RLS	ADDED PART NUMBERS TO CHART	05963	LA	DH
REV	DATE	BY	CHK	DESCRIPTION	ECN #	CUST	PM

PANDUIT

CORP. TINLEY PARK, ILLINOIS

REELSMART™ TERMO™ 2PC. CONTINUOUSLY MOLDED VINYL INSULATED, #16-14 BARREL, RINGS

DRAWN BY CLK CHK'D FS SCALE NONE DRAWING NO. A41068