



ELECTRONICS, INC.
 44 FARRAND STREET
 BLOOMFIELD, NJ 07003
 (973) 748-5089
<http://www.nteinc.com>

NTE7172 NTE7172SM Integrated Circuit Overvoltage Crowbar Sensing Circuit

Description:

The NTE7172 and NTE7172SM are overvoltage protection circuits that protect sensitive electronic circuitry from overvoltage transients or regulator failures when used in conjunction with an external “crowbar” SCR. These devices sense the overvoltage condition and quickly “crowbars” or short circuits the supply, forcing the supply into current limiting or opening the fuse or circuit breaker. The protection voltage threshold is adjustable and can be programmed for minimum duration of overvoltage condition before tripping, thus supplying noise immunity. The NTE7172 and NTE7172SM are essentially a “two terminal” system and, therefore both can be used with either positive or negative supplies.

Features:

- Available in an 8-Lead DIP (NTE7172) or an SOIC-8 surface mount (NTE7172SM) package

Absolute Maximum Ratings:

Differential Power Supply Voltage, V_{CC}	40Vdc
Sense Voltage (1), V_{Sense1}	6.5Vdc
Sense Voltage (2), V_{Sense2}	6.5Vdc
Remote Activation Input Voltage, V_{act}	7.0Vdc
Output Current, I_O	300mA
Operating Ambient Temperature Range, T_A	0° to +70°C
Operating Junction Temperature, T_J	+125°C
Storage Temperature Range, T_{stg}	-65°C to +150°C

Electrical Characteristics: ($5V \leq V_{CC} - V_{EE} \leq 36V$, $0^\circ < T_A < +70^\circ C$, unless otherwise specified)

Parameter	Symbol	Test Conditions	Min	Typ	Max	Unit
Supply Voltage Range	$V_{CC} - V_{EE}$		4.5	-	40	Vdc
Output Voltage	V_O	$I_O = 100mA$	$V_{CC} - 2.2$	$V_{CC} - 1.8$	-	Vdc
Indicator Output Voltage	$V_{OL (IND)}$	$I_{O(Ind)} = 1.6mA$	-	0.1	0.4	Vdc
Sense Trip Voltage	V_{Sense1} , V_{Sense2}	$T_A = 25^\circ C$	2.45	2.6	2.75	Vdc
Temperature Coefficient of V_{Sense1}	TCV_{S1}		-	0.06	-	%/°C

Electrical Characteristics (Cont'd): ($5V \leq V_{CC} - V_{EE} \leq 36V$, $0^\circ < T_A < +70^\circ C$, unless otherwise specified)

Parameter	Symbol	Test Conditions	Min	Typ	Max	Unit
Remote Activation Input Current	I_{IH}	$V_{IH} = 2V, V_{CC} - V_{EE} = 5V$	-	5.0	40	μ
	I_{IL}	$V_{IL} = 0.8V, V_{CC} - V_{EE} = 5V$	-	-120	-180	μ
Source Current	I_{Source}		0.1	0.2	0.3	mA
Output Current Risetime	t_r	$T_A = +25^\circ C$	-	400	-	mA/ μs
Propagation Delay Time	t_{pd}	$T_A = +25^\circ C$	-	0.5	-	μs
Supply Current	I_D		-	6.0	10	mA

Pin Connection Diagram

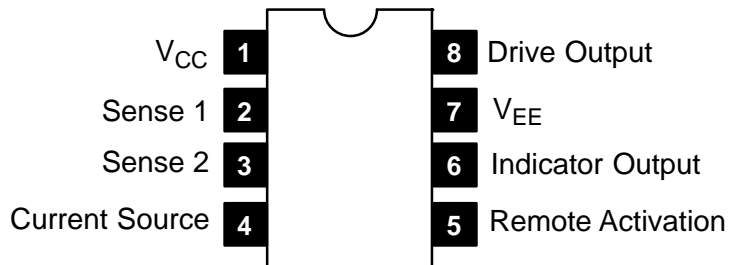

NTE7172

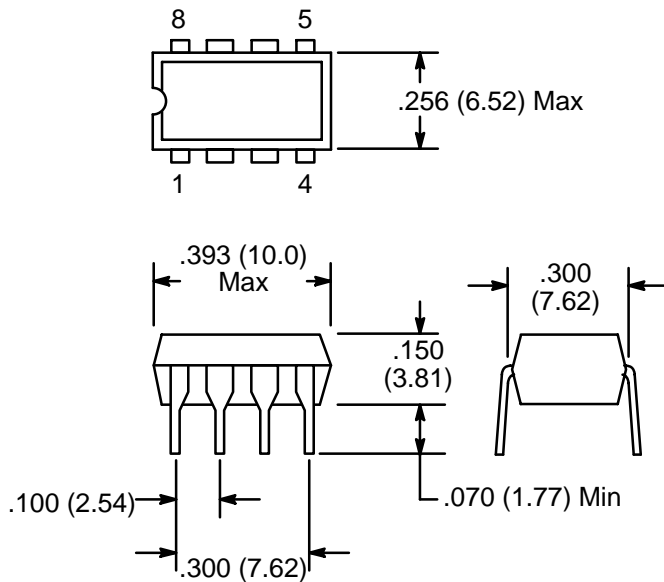

NTE7172SM

