

PART #	øA	øB	øC	øD	øE	FOR WIRE
21-348-0	ø3.2	ø4.55	ø5.6	ø6.5	ø1.0	RG58/u
21-349-0	ø3.9	ø5.5	ø6.4	ø7.3	ø0.8	RG59/u

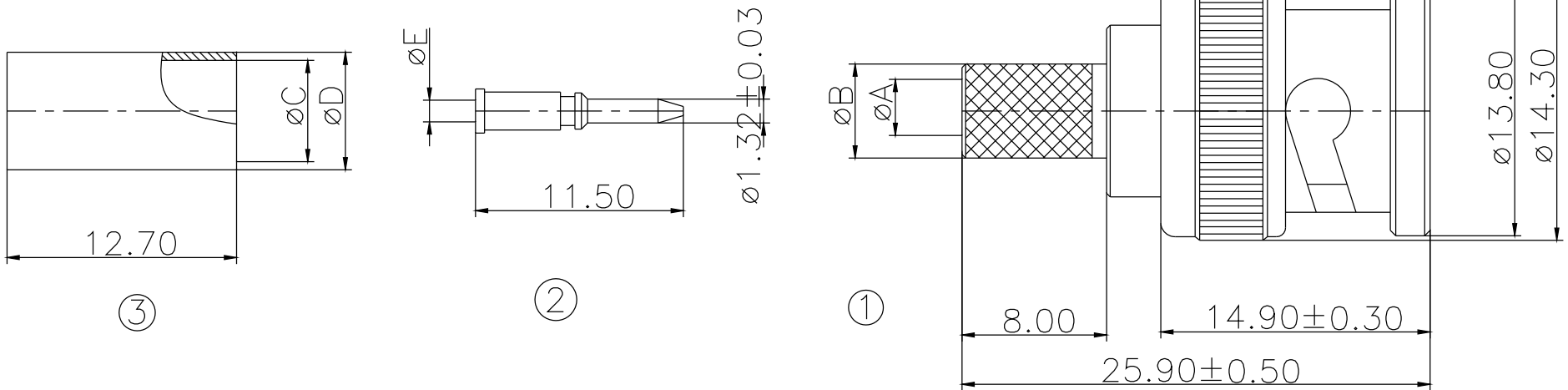

3	SLEEVE	BRASS	1	NICKEL PLATE
2	CENTER CONTACT	BRASS	1	GOLD PLATED
1	BODY	ZINC ALLOY	1	NICKEL PLATE
	WASHER	ZINC ALLOY	1	NICKEL PLATE
	SPRING	65Mn	1	NONE
	OUT CONTACT	ZINC ALLOY	1	NICKEL PLATED
	RUBBER WASHER	PVC	1	NONE
	INSULATOR	POM	1	NONE
	SHELL	ZINC ALLOY	1	NICKEL PLATED
ITEM	DESCRIPTION	MATERIAL	Q'TY	FINISHED

TITLE <b>CRIMP CONNECTOR</b>		SCALE
DRAWING NO. <b>21-348/349</b>		<b>NTS</b>
		UNITS <b>mm</b>
FILE NAME	<i>21-348&amp;349.pdf</i>	SHEET <b>1/1</b>