

SD

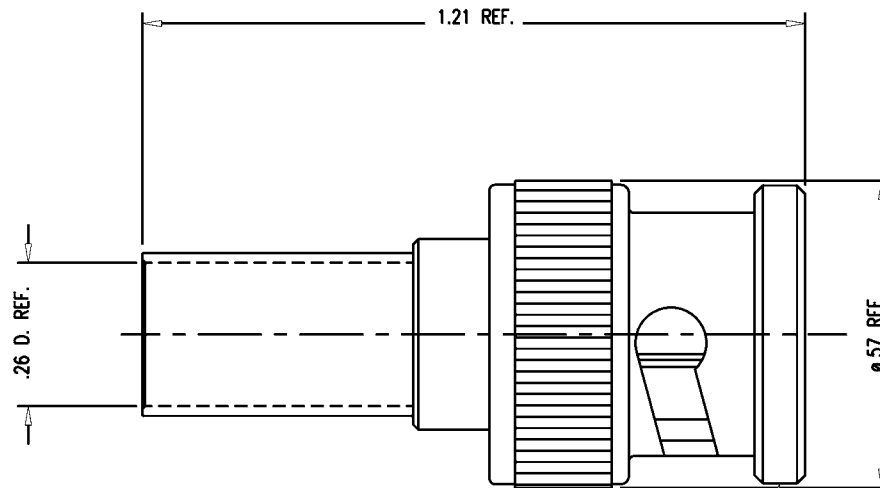

STAMP: KINGS 2065-2-9  
YR WK (DATE CODE)

## NOTES:

1. FOR USE WITH BELDEN 9259 CABLE.
2. FOR CABLING INSTRUCTIONS SEE 3-661-1.
3. FOR CABLE TRIMMING USE KTJ-57 & KTD-26.
4. FOR CRIMPING USE DIE KTH-2261.
5. INTERFACE PER KINGS ES-17, FIG. 6.
6. MATERIALS:
  - INSULATOR-TEFLON, ASTM-D-4894
  - GASKET-SILICONE RUBBER, ZZ-R-765
  - SPRING WASHER } BER. COP., ASTM-B-196
  - OUTER CONTACT }
  - K-GRIP SLEEVE-COMMERCIAL BRONZE, ASTM-B-135
  - ALL OTHER METAL PARTS-BRASS, ASTM-B16
7. FINISHES:
  - CENTER CONTACTS-GOLD PLATE PER MIL-G-45204
  - SPRING WASHER-SILVER PLATE PER QQ-S-365
  - ALL OTHER METAL PARTS-KINGS TARNISH RESISTANT NICKEL FINISH (TR-5)
8. ELECTRICAL CHARACTERISTICS:
  - NOMINAL IMPEDANCE-75 OHMS
  - WORKING VOLTAGE-500 VRMS
  - FREQUENCY RANGE-DC TO 3 GHZ

SD

2065-2-9

REVISIONS	
ISSUE	CHANGES
0	ER 37767 DCT 01/11/99
1	CN 37782 E DCT 01/29/99
2	CN 37793 A TML 02/16/99
3	CN 37804 E TML 04/01/99
4	CN 37836 C TML 05/20/99
5	CN 37932 D REDRAWN TML 11/08/99
6	CN 38011 D HVN 05/23/00
7	CN 38073 C TML 08/28/00
8	CN 38334 D TML 06/20/01
9	CN 38495 E TML 02/01/02
206529S	
SCALE 4:1	
APPROX SURFACE AREA	
USED ON	
REF:	
PL, 75 BNC	
DRAWN TML	DATE 01/11/99
DESIGN DCT	DATE 01/11/99
APPR.	DATE
<b>KINGS</b> ELECTRONICS CO., INC. ROCK HILL, SOUTH CAROLINA 29730	
2065-2-9	