

**90° Standard Slide-On Strain Relief Cover Kit  
(for 50 Position Only)**

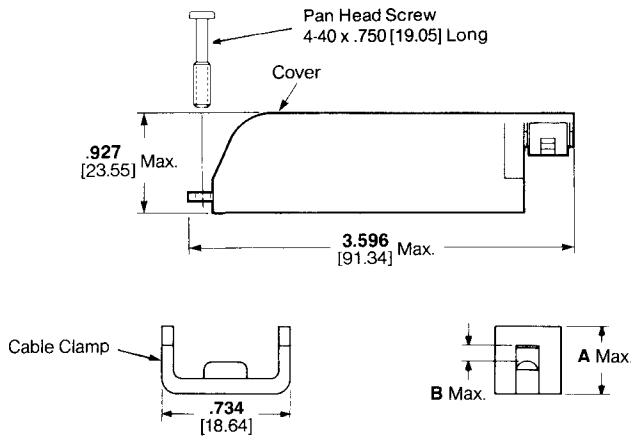

**90° Tapered Slide-On Strain Relief Cover Kit  
(for 50-Position Only)**

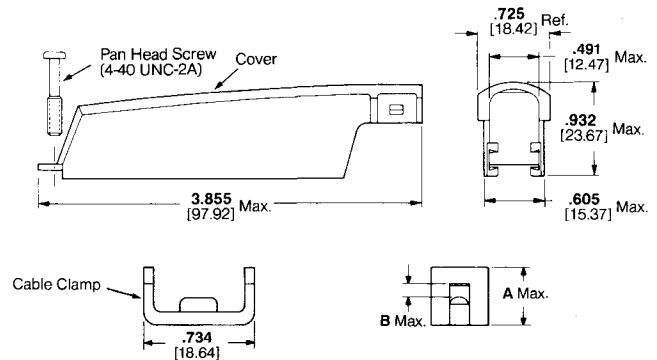

Cable Range Diameter	Dimensions		Kit Part Numbers		Component Part Numbers			
	A	B	Standard Cover	Tapered Cover	Cable Clamp	Screw	90° Tapered Cover	90° Slide-On Cover
.425-.500 10.80-12.70	.475 12.07	.202 5.13	552960-1	552560-5	1-229910-1	229911-1	229909-1	552617-1
.350-.425 8.89-10.80	.380 9.65	.107 2.72	552960-2	552560-1	229910-1	229911-1	229909-1	552617-1
.325-.370 8.26-9.40	.380 9.65	.057 1.45	—	—	2-229910-1	229911-1	229909-1	552617-1
.300-.325 7.62-8.26	.380 9.65	.022 .056	—	—	3-229910-1	229911-1	229909-1	552617-1
.500-.550 12.70-13.97	.540 13.72	.267 6.78	552960-5	—	4-229910-1	229911-1	229909-1	552617-1

**90° Standard Slide-On Strain Relief Cover and Adjustable Cable Clamp (for 50-Position Only)  
(recommended for use with CHAMP-LOK Connector or Screw Lock hardware)**

**Cable Dia.** — .425 [10.80] Max.  
**Cover** — Black—Part Number 552760-1,  
 Gray—Part Number 552760-2  
**Cable Clamp** — Black—Part Number 552763-1,  
 Gray—Part Number 552763-2

